



PQ Solutions

MV Equalizer

RealTime Power Factor
Correction System
at Medium Voltage



Espec MV Equalizer System

Espec MV Equalizer is a power factor correction system for dynamic loads at Medium Voltage with extreme fast variations of reactive power demand. It continuously provides real-time response for Reactive Power, Harmonics, Voltage drops, flickering and as a result supports grid's stability. The Equalizer system uses ultra-high power medium voltage thyristor switching technology, providing transient-free smooth switching by connecting capacitors at zero-crossings. Elspec offers wide range of MV power factor correction systems up to 115MVar. The systems can be operated indoor as well as outdoors.

The Need for Medium Voltage (MV) Compensation

Compensation at MV is mostly recommended when the reactive power consumption is higher than 1000 KVar and extreme fast variations of reactive power are needed. Stable consumption with variation of consumption can be treated as well. From a different aspect, using MV system enables a more economical use of electrical power through the utilization of smart grids.

Voltage Stabilization & Real-Time Compensation for High Efficiency

Installing the MV Equalizer system at one or more points of the grid will enhance voltage stability for networks with rapid loads and will prevent machinery downtime. The ability to perform real-time compensation with high efficiency of 99.2% makes the MV Equalizer one of the most efficient solutions in the market today.

Power Factor Compensation – A Comparison The Equalizer is an ideal solution for power quality applications. Regardless of the application, the equalizer solution achieves near- perfect power factor control, network stabilization and efficiency improvements. In many cases, the equalizer is the only proper solution: Implementing quasi-real-time systems in these applications would actually reduce power quality and possibly produce wasted energy. The following example compares the results of the Equalizer (2/3 cycle typical) with a quasi-real time solution (1 step per 3 cycles).

Correct Compensation Using the Equalizer Graph A demonstrates the Equalizer's compensation of the reactive current in a 14- cycle load. Typical acquisition time (full compensation of reactive current) is less than once cycle and total current is substantially reduced.

Incorrect Compensation Using Slow Response Systems

Graph B demonstrates incorrect compensation where response time is 1 step per 3 cycles to connect a single group and acquisition time required to connect a total of 4 groups is 12 cycles. Due to the delay in connections, the current is only partially reduced. Further, the corresponding delay in disconnection causes residual current. The overall effect of this compensation system on total current is negative, as the average current of the load is increased, rather than decreased. This phenomenon can also increase voltage flickering due to overcompensations.

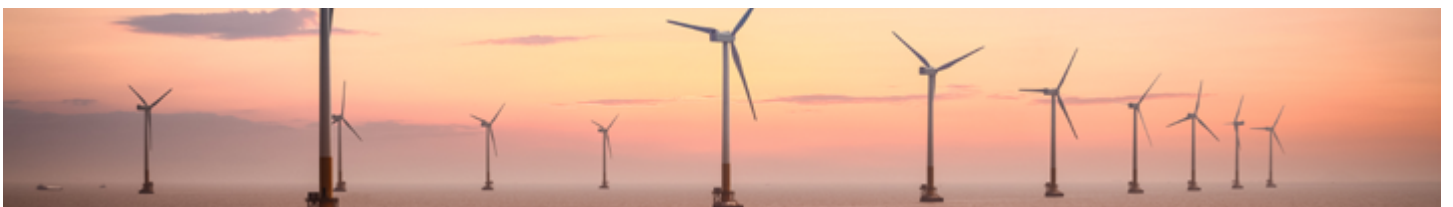
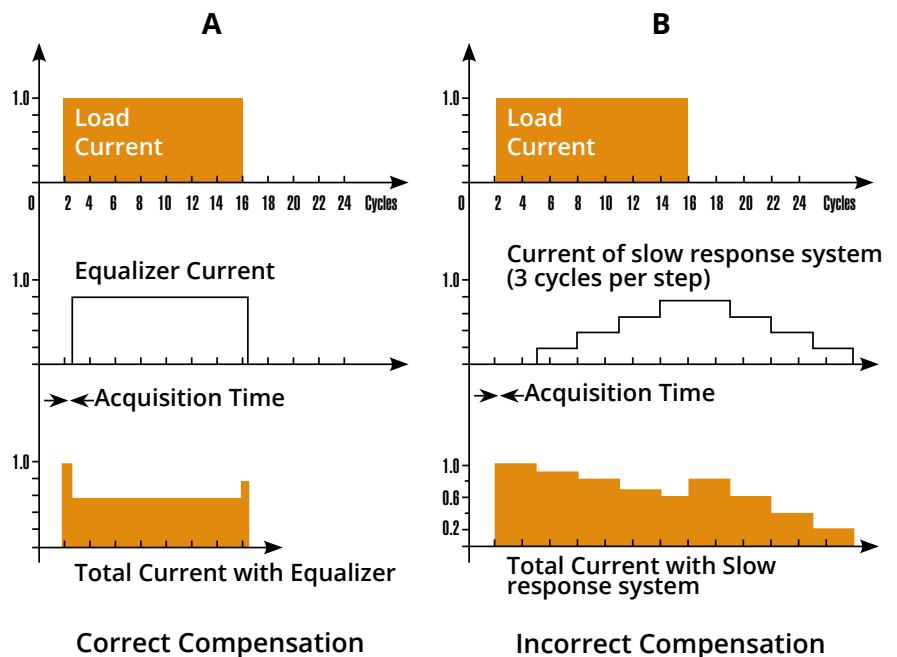

Key Components

PFC Control Section

The control section of the MV Equalizer contains a controller and 2 Digital Fault Recorders (DFR).

The controller

The controller is the brain of the system. Based on an advanced VLSI device and a Digital Signal Processor (DSP), it carries up to 9 channels (4 voltages, 3 network currents and 2 system currents). The control function of the controller constantly samples the currents and voltages and analyses the precise capacitor groups required to obtain an accurate power factor or kVAR demands in systems in order to adjust the voltage level and to reach the power factor requirements.

The controller uses FFT (Fast Fourier Transform) analysis of all phases each cycle. Power information, system status and detailed logs of events are displayed on a large backlit graphic LCD screen, or via communication using the user-friendly PQSCADA Sapphire software.



DFR - Digital Fault Recorders

The MV Equalizer control system is equipped with 2 DFR units or more with trigger-free PQZIP technology (Patented). Each DFR is comprised 16 measurement channels, 9 of them for continuously recording of the internal current of capacitors groups, in all 3 phases for each group.

Mains, Loads and Capacitors groups' status and monitoring (one DFR or more)

This information enables to detect and follow harmonics in each one of the capacitors groups and to follow the kVAR status (reduction of kVAR during time) by measuring the percentage of the kVAR comparing to the design. In addition it will be possible to follow the response of each group to any change of reactive energy. The DFR recording capacity (cycle by cycle) allows to identify the source of failure in case it happens in a capacitors group, load or in the external network.

Capacitors group - I²t Protection (one DFR or more)

The DFRs are equipped with I²t protection for each one of the thyristors switching elements Valve which is used to switch the capacitors groups. This feature allows to avoid developments of a malfunction in case of a temporary failure and to disable a capacitor group in case of a permanent failure in order to avoid further development of a failure.



PQ ZIP inside



Superior Transmission Rate



P&M Class Simultaneously



Synchronized Monitoring

Key Components

Valve (Thyristor Switch)

The Equalizer uses ultra-high power medium voltage Valves, providing transient-free smooth switching by connecting capacitors at zero-crossings.

The Valves connect and disconnect the capacitor groups by fiber optic signals issued by the controller. Each valve has several thyristor pairs in series (their quantity depends on the working voltage and topology) with additional elements in parallel to each thyristor pair. The valves receive fiber optic firing commands, and connect the capacitors at current zero crossings.

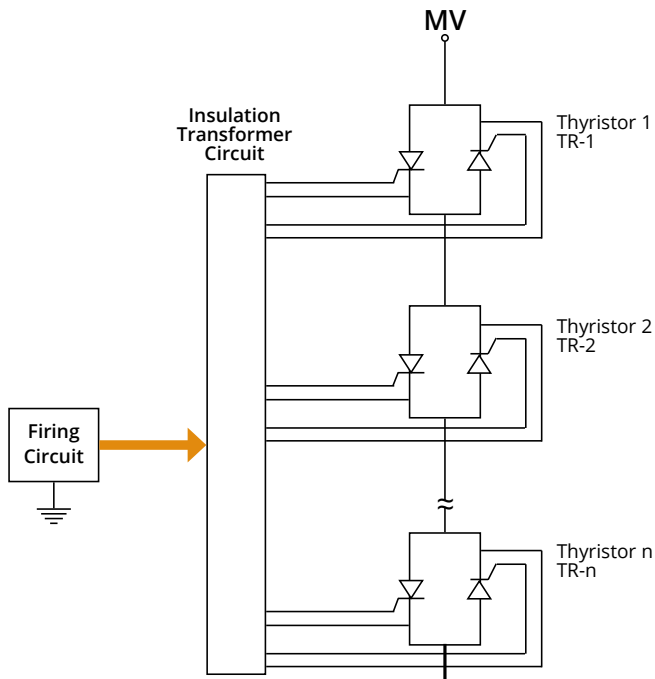

MV Thyristor Switching (Valve) Electrical Diagram

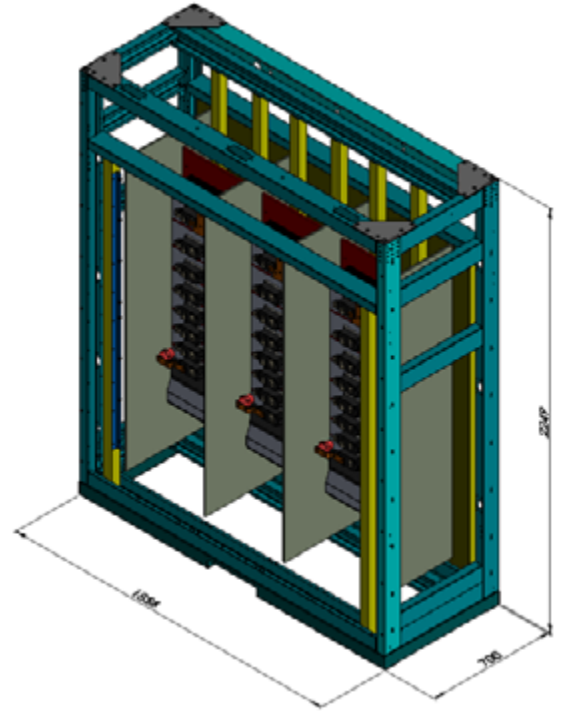

MV Three phase Thyristor Switching (Valve)

Typical Applications

- Power utilities
- Water utility (water pumps)
- Solar farms
- Wind farms
- Arc furnaces

- Lumber mills
- Welding operations
- Car crushers & shredders
- Mining mills, shovels and hoists
- Port cranes



MV Application Example

Motor Start-Up

Mitigating Voltage Sags

The most common cause of over currents leading to voltage sags are motor startups. One of the main design features of the MV Equalizer is the ability to mitigate voltage sags during motor startup operations. As demonstrated in the diagram below, it is able to do so by injecting reactive power, for the given voltage sag magnitude at the required compensation period. This diagram includes a transformer [T] its impedance [X_{LT}, R_{LT}], an additional line [X_L, R_L] the MV Equalizer [X_C] and the load [R_{LOAD}, X_{LOAD}].

During a voltage sag the source input [U₀] drops to a substantial lower level [U₁]. As soon as the voltage sag starts, the MV Equalizer immediately connects in order to create total leading current [Orange]. Once it is connected the voltage drop on the resistive part is synchronized with the total current, shifting in a counter-clockwise [opposite] direction. Subsequently, the voltage drop on the inductive part also shifts to 90°, resulting in a substantially lower [U₀].

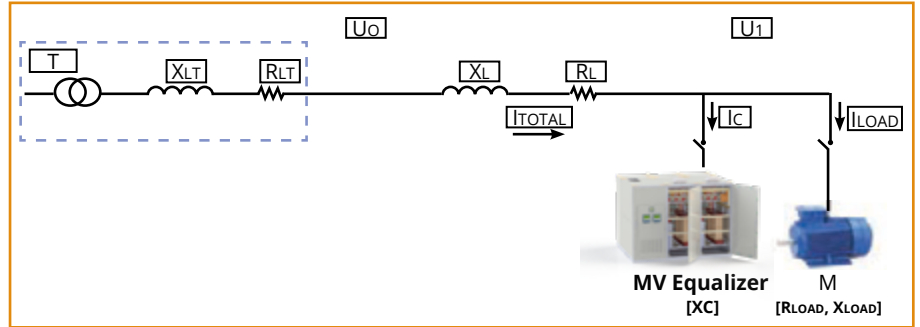

Optimizing Network Power Quality and System Performance

The MV Equalizer minimizes the motor's startup period, thereby avoiding unnecessary wear to the motor and simultaneously extending the motor's life expectancy. The system also improves the overall power quality of the network, by reducing harmonic levels and introducing transient-free switching. It also significantly reduces the startup current, thereby securing a safe and successful startup of the motor.

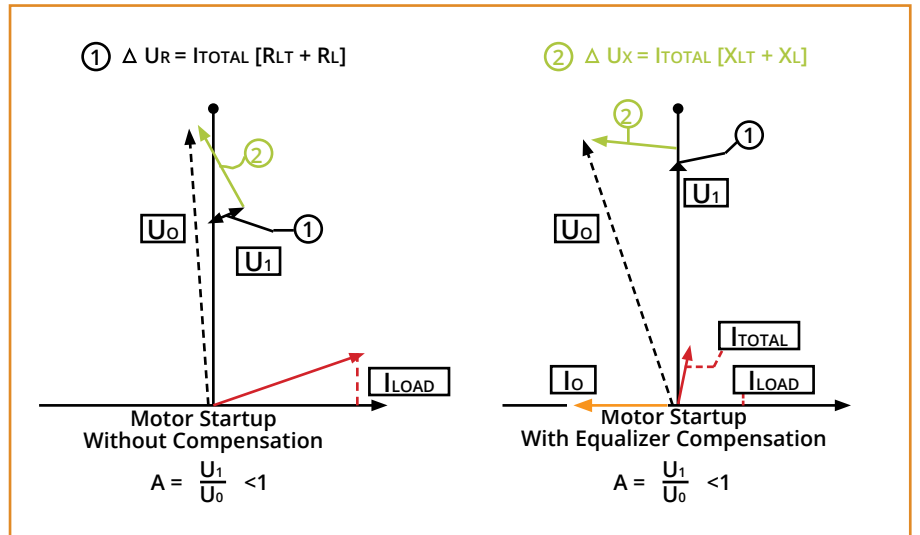

Water pump station at Mekorot Israel



MV Application Example

Motor Start-Up

MV Equalizer - 1.5 MW

Demonstration of Acquisition Time - 1 Cycle

Actual Measurement without Compensation

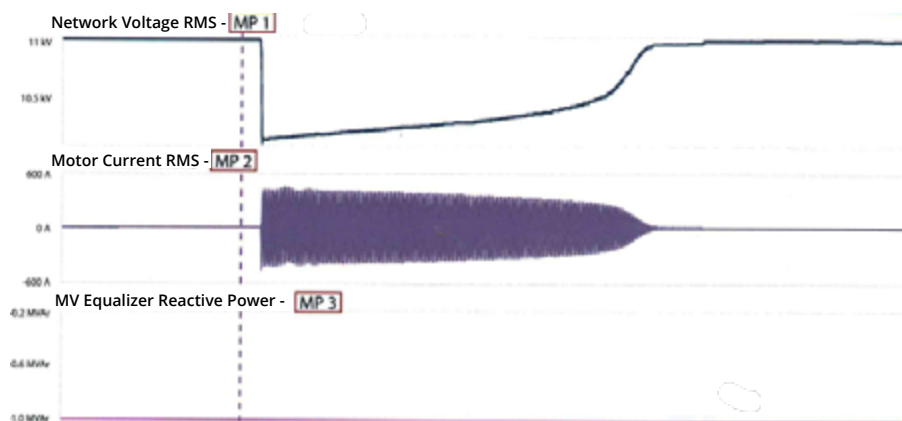

Actual Measurement with Compensation

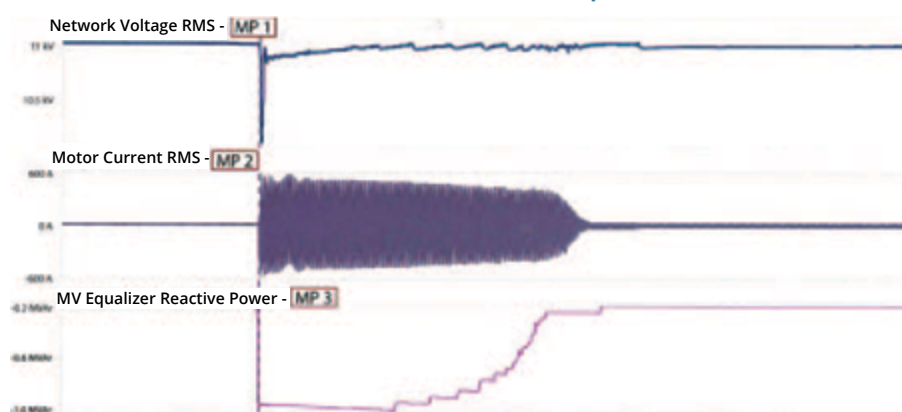

Actual Electrical Diagram

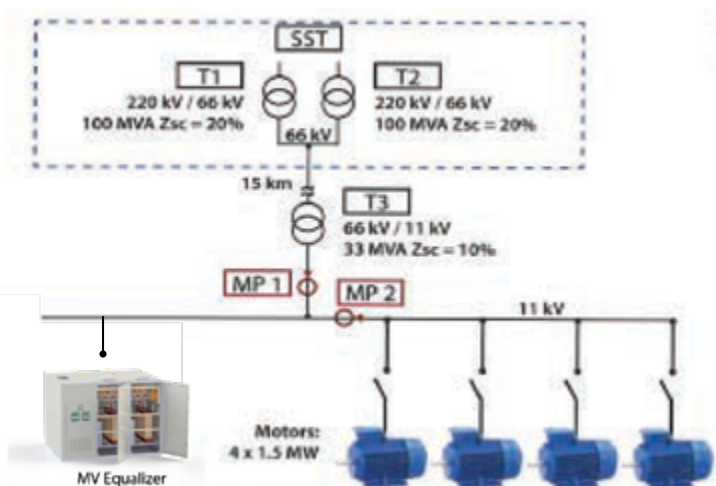

*MP = Measurement Points

Measured Values Without & With Compensation

Parameters	Without Compensation	With Compensation	Improvement
Total voltage sag during start-up at 66 kV AU %	-4.1%	-1.42%	65%
Total voltage sag during start-up at 11 kV AU %	-8.8%	-2.8%	68%
Total current at 11kV	580 Amp	280 Amp	51%

MV Project Examples

Installing The MV Equalizer Samsung

Elspec MV Equalizer 3MVAR system was installed in Samsung South Korea to compensate the power and stabilize the network. The plant with its sensitive equipment, experienced electric disturbances and shutdowns caused by voltage drops and harmonic distortions. The MV Equalizer system eliminates equipment failures caused by voltage drops, improves voltage stabilization, and enables standard regulations compliance. The ability to perform real-time compensation with high efficiency (low losses) makes the Elspec MV Equalizer one of the most efficient solutions in the market today.



Specifications

MV Equalizer System	Manufacturer	Elspec Ltd.
	Enclosure Type	Indoor or Outdoor
	Design Ambient Temperature (Elec. Room)	Indoor/Outdoor : 5~40°C
	Design Relative Humidity	Max.95%
	Nominal voltage	Up to 22kV
	System Losses	≤0.8%
	Rated maximum voltage	1.1 UN - 12 Hours Per Day 1.15 UN - 0.5 Hour Per Day 1.2 UN - 5 Minutes / 200 Times 1.3 UN - 1 Minute / 200 Times
	Phase & Frequency	3Ph, 50/60Hz
	Protection Degree	IP54 mounting in sealed 20FT container or Indoor IP21
	Buses	
Bus material	Copper	
Bus Coating	Tin coating	
Bus Insulation	Heat Shrinkable Tube	
Nominal current	Depending on system power and voltage level	
Thyristor Valve Panel	Valve	
	Manufacture	Elspec Ltd.
	Enclosure	Valve Enclosure: Indoor, Self-standing
	No of Valves per group	Wye: 3 (1 per phase), Delta 2
	Voltage Ratings	
	Nominal voltage	1.2kV - 22kV
	Rated maximum voltage	According to IEC or UL
	Valve Current Ratings	
	Rated continuous current	150A without cooling, 250A with direct cooling fan
	Rated short time current carrying capacity & duration	4000Amp during 10mSec
Zero crossing- connection / disconnection	Transient free, connection and disconnection of capacitors. Carried out during current zero crossing., Therefore there is no limitation on number of operations.	
Acquisition time (full compensation to required PF)	One cycle full compensation within 16.6mSec on 60Hz and 20mSec on 50Hz networks	
PF Rated continuous current	1.3 x In per capacitor groups	
Power frequency withstand voltage (kV)	According to IEC 61936-1:2021 For 3.6kV (Um) - 10kV For 7.2kV (Um) - 20kV For 12kV (Um) - 28kV For 17.5kV (Um) - 38kV For 24kV (Um) - 50kV	
1.2/50 microsec.impulse volt withstand (kV)	According to IEC 61936-1:2021 For 3.6kV (Um) - 40kV For 7.2kV (Um) - 60kV For 12kV (Um) - 95kV For 17.5kV (Um) - 95kV For 24kV (Um) - 125kV	
Internal Wire Type	SIS or XHHW equivalent	
Cable Entry	Top or Bottom	
Standards	IEC 62271-1, IEC 62271-200	
Capacitors	Heavy Duty	Significant voltage derating factor (and consequent of stress free design considering actual rated system voltages)
	Details of foil material	Film- foil type, oil impregnated
	Material	Aluminum foil
	Details of impregnant	NPCB
	Dielectric strength of impregnant.	> 70 kV/2.5 mm gap (based on standard IEC electrode)
	Residual voltage (V)	≤75V
	Discharge time (msec)	6000mSec
	Dielectric losses (excluding discharge resistances & othe losses)	0.1W/kVAR
	Tangent of dielectric loss angle (tan)	≤2 x 10 ⁻⁴
	Rated output voltage (V)	TBD (depending Nominal Voltage)
	Inrush Current (A)	VCB :MP, Thyristor : 12.7P
	Temperature rise (Maximum °C)	VCB :MP, Thyristor : 12.7P
	Type of connection	Multistage Thyristor
	Rated maximum voltage	1.1 UN - 12 Hours Per Day 1.15 UN - 0.5 Hour Per Day 1.2 U - 5 Minutes / 200 Times 1.3 U - 1 Minute / 200 Times
	Peak Current	100In
	Power frequency withstand voltage (kV)	According to IEC 61936-1:2021 For 3.6kV (Um) - 10kV For 7.2kV (Um) - 20kV For 12kV (Um) - 28kV For 17.5kV (Um) - 38kV For 24kV (Um) - 50kV
	1.2/50 microsec.impulse volt withstand (kV)	According to IEC 61936-1:2021 For 3.6kV (Um) - 40kV For 7.2kV (Um) - 60kV For 12kV (Um) - 95kV For 17.5kV (Um) - 95kV For 24kV (Um) - 125kV
	Standards	IEC 60871-1-2014

Series Reactor	Designer	Elspec Ltd.
	Type of core	Dry type
	Isolation class	class H, 180°C
	Number of phase	1
	Rated frequency	50Hz / 60Hz
	Type of cooling	NATURAL
	Detuned factor	7% / 14%
	Linearity	1.8 In
	Power losses at 75°C (total in all 3 phases)	≤0.2%
	Maximum tTemp. rise for winding Oil & resistance method (°C)	class H, 70°C
	Power frequency withstand voltage (Hz) phase to ground	TBD (depending Nominal Voltage)
	1.2/50 microsec.impulse volt withstand (kV) phase to ground	TBD (depending Nominal Voltage)
	Power frequency withstand voltage (Hz) phase to core	TBD (depending Nominal Voltage)
	1.2/50 microsec.impulse volt withstand (kV) phase to core	TBD (depending Nominal Voltage)
	Noise	<65db
	Protection class	IP 00
	Iron Core	Silicon steel
	Winding material	Enmeled copper wire
	Terminals	Copper bar
	Ambient Temperature	-25°C to +50°C
	Impregntation	Vacum Vernish Impregntation (VPI?)
	Resonance frequency with capacitor bank (Hz)	50Hz - 189Hz, 60Hz - 227Hz
Standards	IEC/EN60076-6, EN61558-2-20	
Current Transformer (Internal Cap Measurement)	Primary Current (I)	250% from nominal current
	Secondary Current (I)	5Amp
	Connection	3 Phases
	Rated output & Accuracy class	0.50%
	Power frequency withstand voltage (Hz)	TBD (depending Nominal Voltage)
	1.2/50 microsec.impulse volt withstand (kV)	TBD (depending Nominal Voltage)
	Weight	30kg App
Standards	IEC60044-1, GB20840.1-2010, GB20840.2-2014	
Protection features and indication	Unit protection	DIGITAL RELAY with VCB / P.F
	Indication for ON/OFF condition of capacitor	On controller LCD screen
	Trip Interlock for accidental opening of capacitor room	Integral
	Discharge device	Resistor on Cacpacitor for maintnece purpose
LV Equalizer Panel	EQ Controller (G3)	
	General	Real Time Controller of the EQ system with acquisition time 1 cycle
	Standards	Safety: ENA61010-1, ENA60439-1, UL-508 EMC: EN50081-2, EN50082-2, EN51000-4-2/3/4/5, ENV50204, ENV50141
	Elspec Digital Fault Recorder No' 1	
	General	One year cycle by cycle recording of all three phases of mains, load and capacitors
	Standards	Refer to multi functional recording specification
	Scada	Refer to management software specification
	Elspec Digital Fault Recorder No' 2	
	General	One year cycle by cycle recording of all three phases on each group. I ² t equivalent protection for each thyristor vlave (two phases on each group)
	Standards	Refer to Multi Functional recording specification
	Scada	Refer to Management software specification

Project Examples



MV Equalizer system in a hospital, USA



161kV Voltage Monitoring in a Range of +3%, Australia

Electrical Diagrams

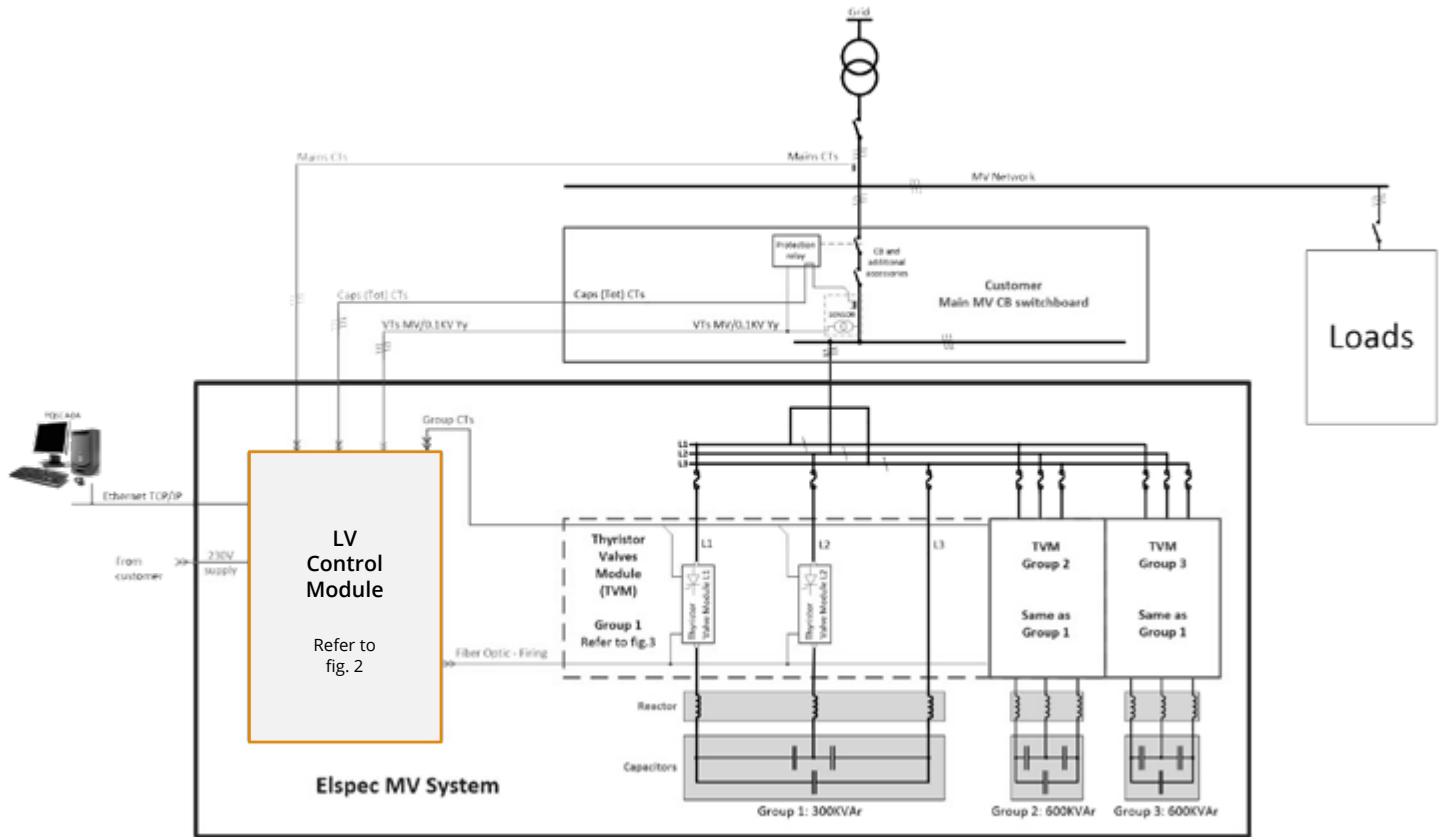

figure 1 - Overall electrical diagram

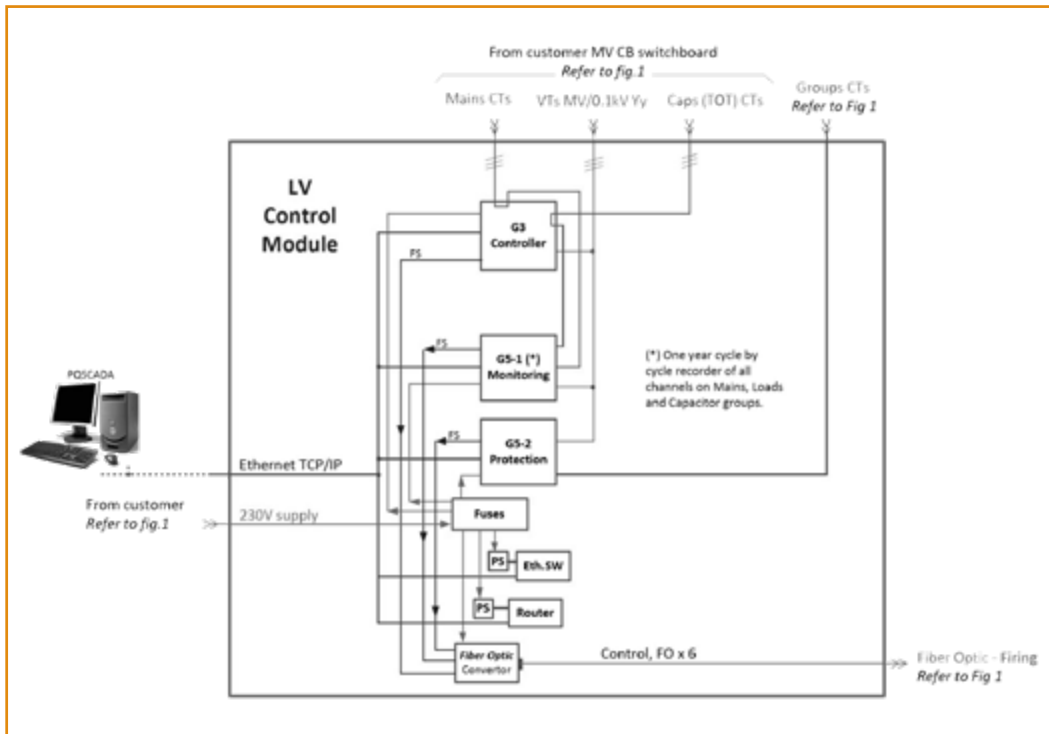
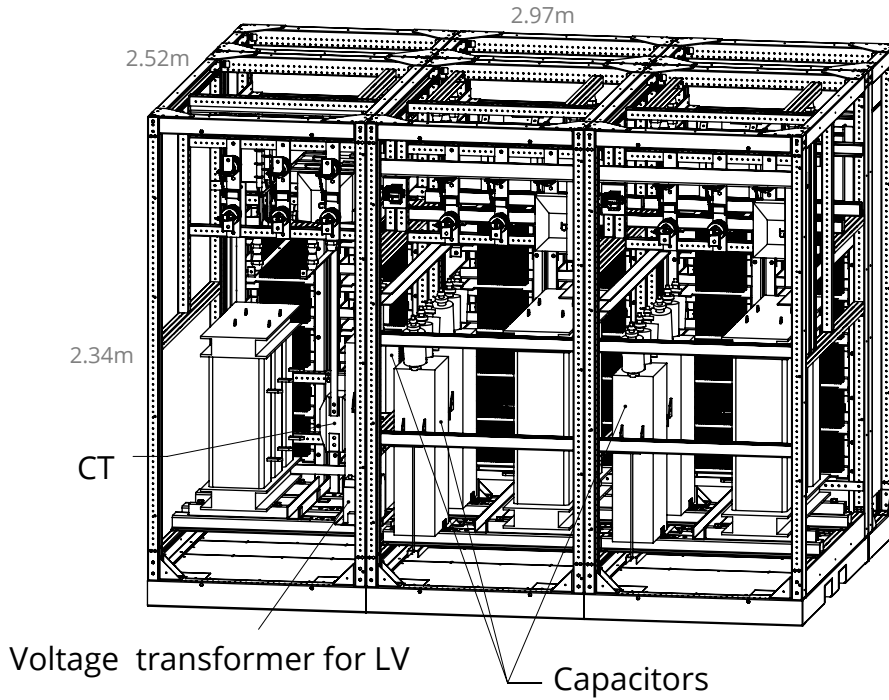

figure 2 - LV control module

Mechanical Diagrams

Indoor System



Tailor Made Solutions

Our MV Equalizer solutions are tailor made for our customers' specific needs. Our high performance systems are easy to install with long life expectancy and low maintaining cost.

Outdoor System in Container

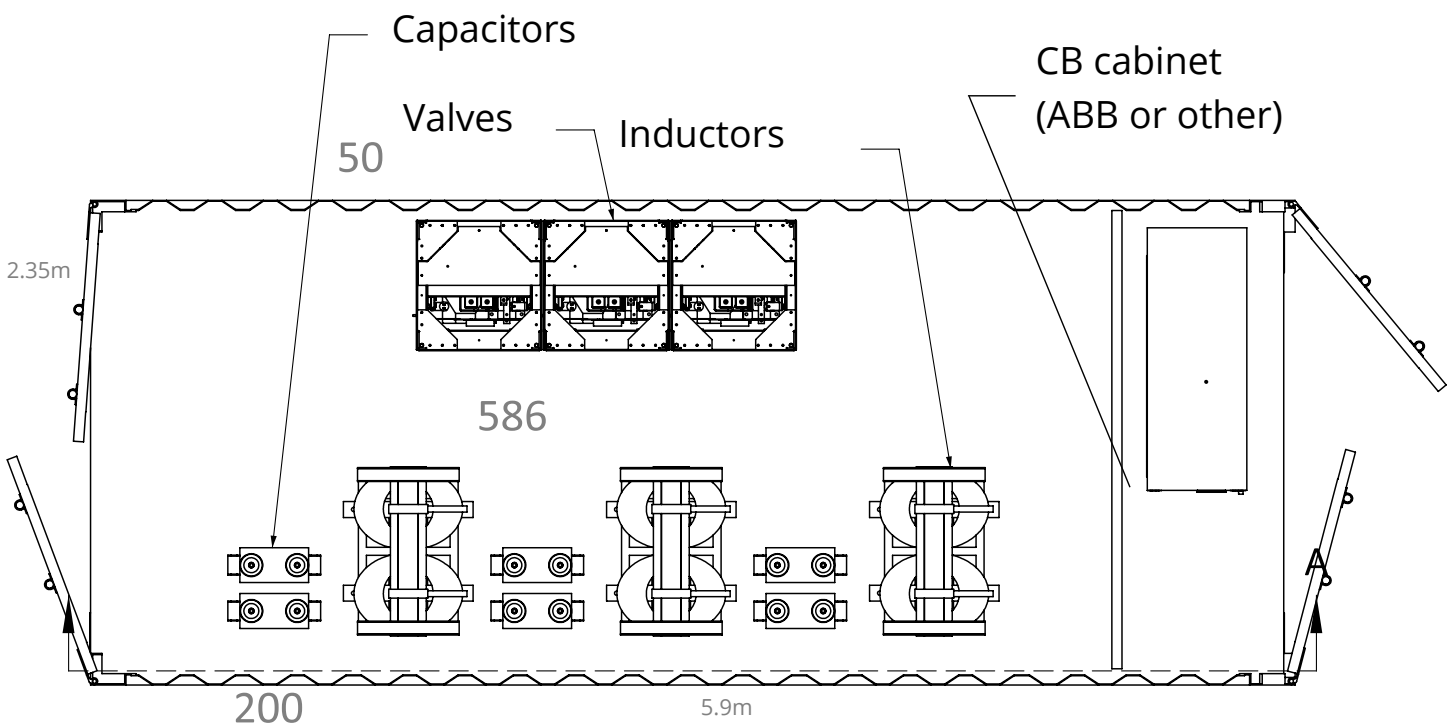

Worldwide Innovator in Power Quality

Since 1988 Elspec has developed, manufactured and marketed proven power quality solutions far exceeding our clients' needs and expectations. Our innovations not only simplify the understanding of the quality of power itself, but are also highly compatible, making it suitable for any business and/or application. Elspec's international team of professionals with extensive experience in electrical engineering, are ready to provide a tailor-made strategy that will enable a sustainable and efficient use of your electrical energy.



International

Elspec Ltd.
info@elspec-ltd.com

North America

Quality Energy
info@quality-energy.com

Europe

Elspec Portugal Lda.
info@elspeceurope.com

India

Elspec Engineering India Pvt Ltd.
info@elspec.in

Región Andina

Elspec Andina
info@elspec.com.co

For all Products & Applications Visit us at:
www.quality-energy.com



Elspec is a registered trademark. All trademarks are the property of their respective owners.
July 2025