

Case Study

Diagnosing Ground Fault Protection Issues in Data Centers with Elspec's Advanced Power Analysis



Elspec's G4500 Power Quality Analyzer and PQSCADA Sapphire power management software were instrumental in diagnosing and analyzing the root cause of disruptions in data center operations in Brazil, uncovering how the misidentification of faults by the ground leakage protection (GS) system affected overall operations.

The Customer Situation

A data center in Brazil experienced frequent trips and shutdowns of its electrical system, yet the source of the issue remained undetermined. These unexpected outages disrupted operations, compromising the facility's ability to provide uninterrupted service for its mission-critical systems. Given the importance of maintaining a reliable power supply, the data center's management faced mounting pressure to identify and resolve the underlying problem.

For data centers, the impact of power quality issues is significant. These facilities rely heavily on a constant, stable power source to support critical infrastructure like servers, storage systems, and communication networks. Power disruptions, even for brief moments, can result in data loss, operational delays, and in some cases, damage to sensitive equipment. As a result, any fluctuation or misinterpretation of the electrical protection system's response can have costly consequences.

The customer approached [AÇÃO Engenharia](#), Elspec's agent in Brazil, for assistance in investigating the root

cause of the issue. ACO's engineering team deployed Elspec's G4500 [Power Quality Analyzers](#) at key points in the system. The G4500 analyzers, with their continuous waveform recording capabilities and high-resolution measurements, provided detailed insights into the electrical behavior.



G4500 Portable Analyzer

Simplified diagram of power supply and loads

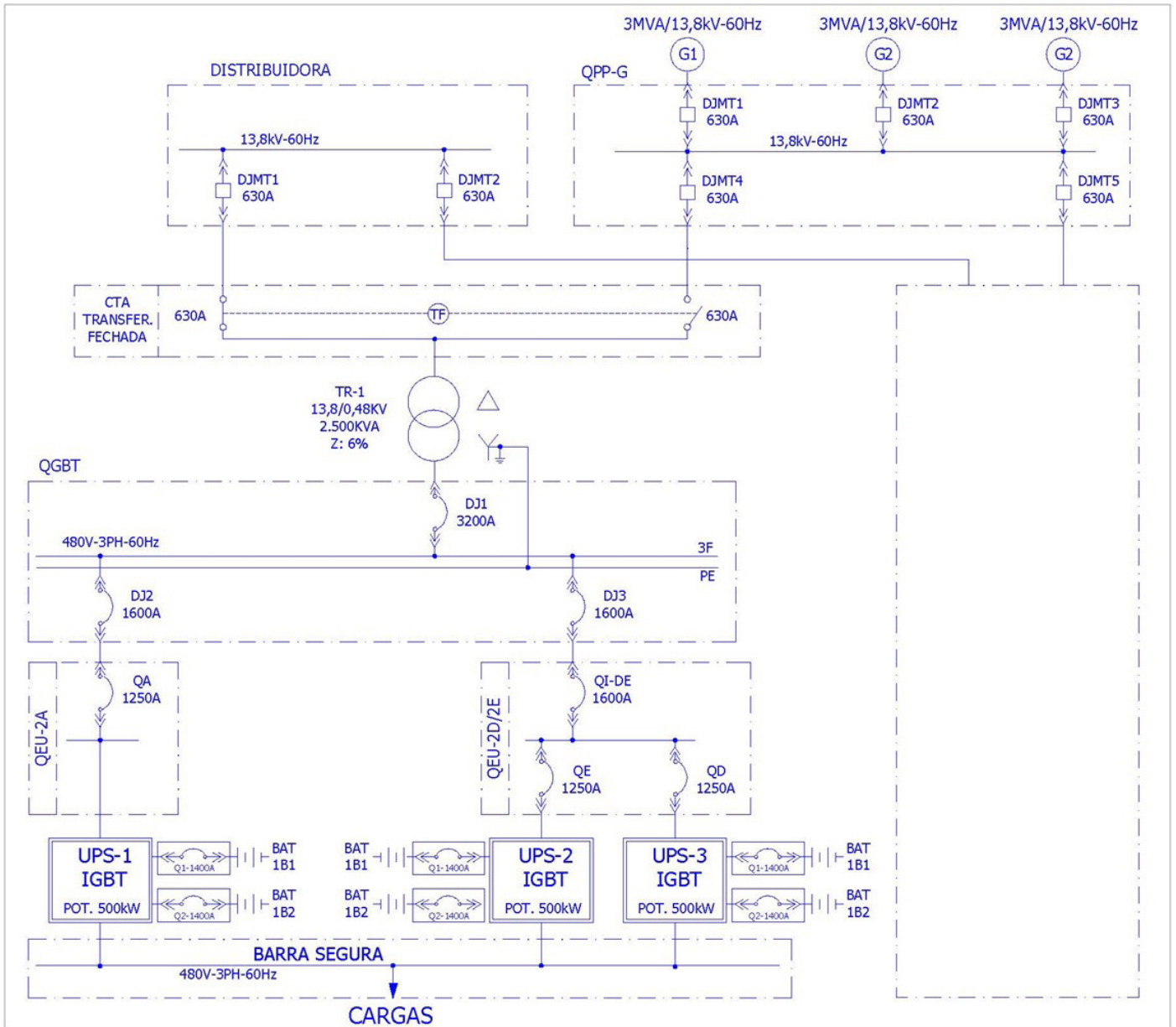

Point of measurement

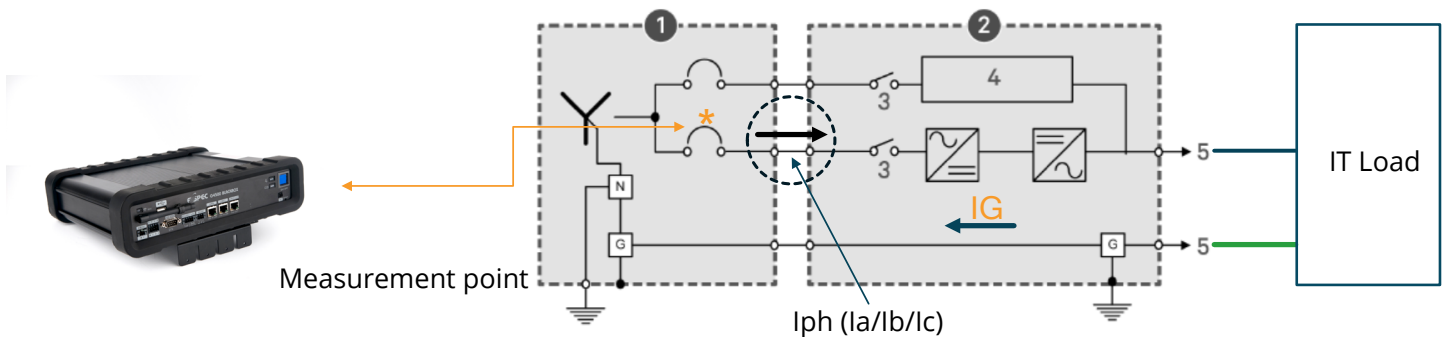

1. Trafo Block/LV Protection (*) CB Opening
2. UPS Block (Rect/Inv) - 3ph load
3. Switching systems
4. STS and bypass
5. Output for load and grounding

Advanced Power Analysis with Elspec's Analyzers and Software

With the data collected, ACAO's team then turned to Elspec's [PQSCADA Sapphire software](#) for in-depth power analysis. This advanced software platform allows to visualize and analyze the complex data from the G4500 analyzers and more than 5000 power parameters, such as harmonic currents, voltage fluctuations, leakage currents in all frequencies and transient events on a synchronized analysis platform.

The measurements are synchronized on the following graphics.

Voltage measurement:

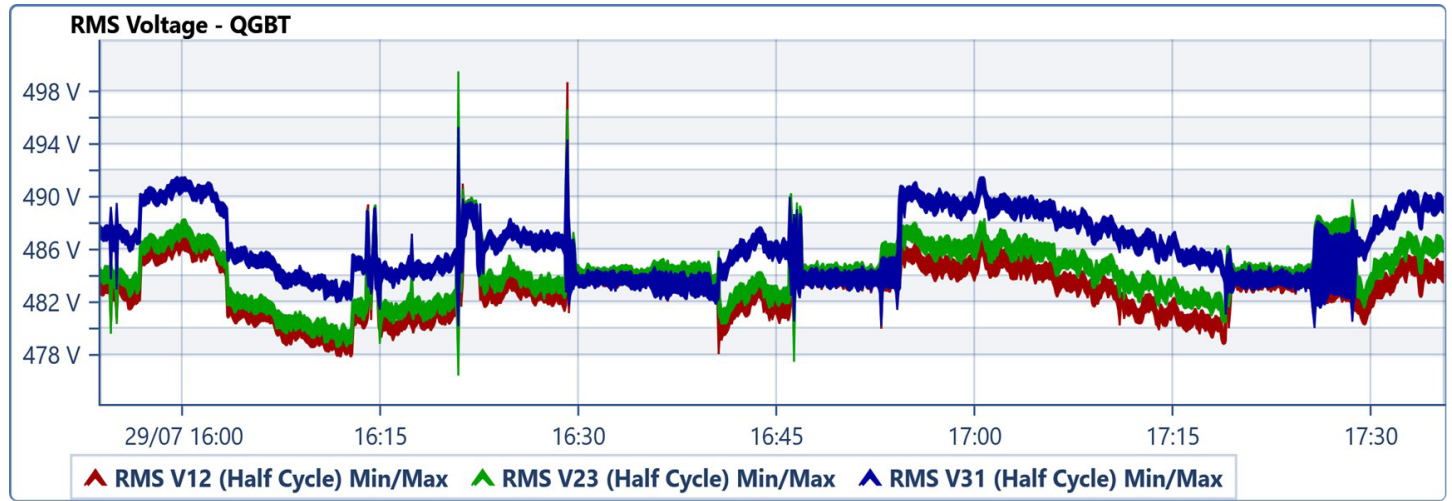

Load Current measurement:

Current with disabled protection

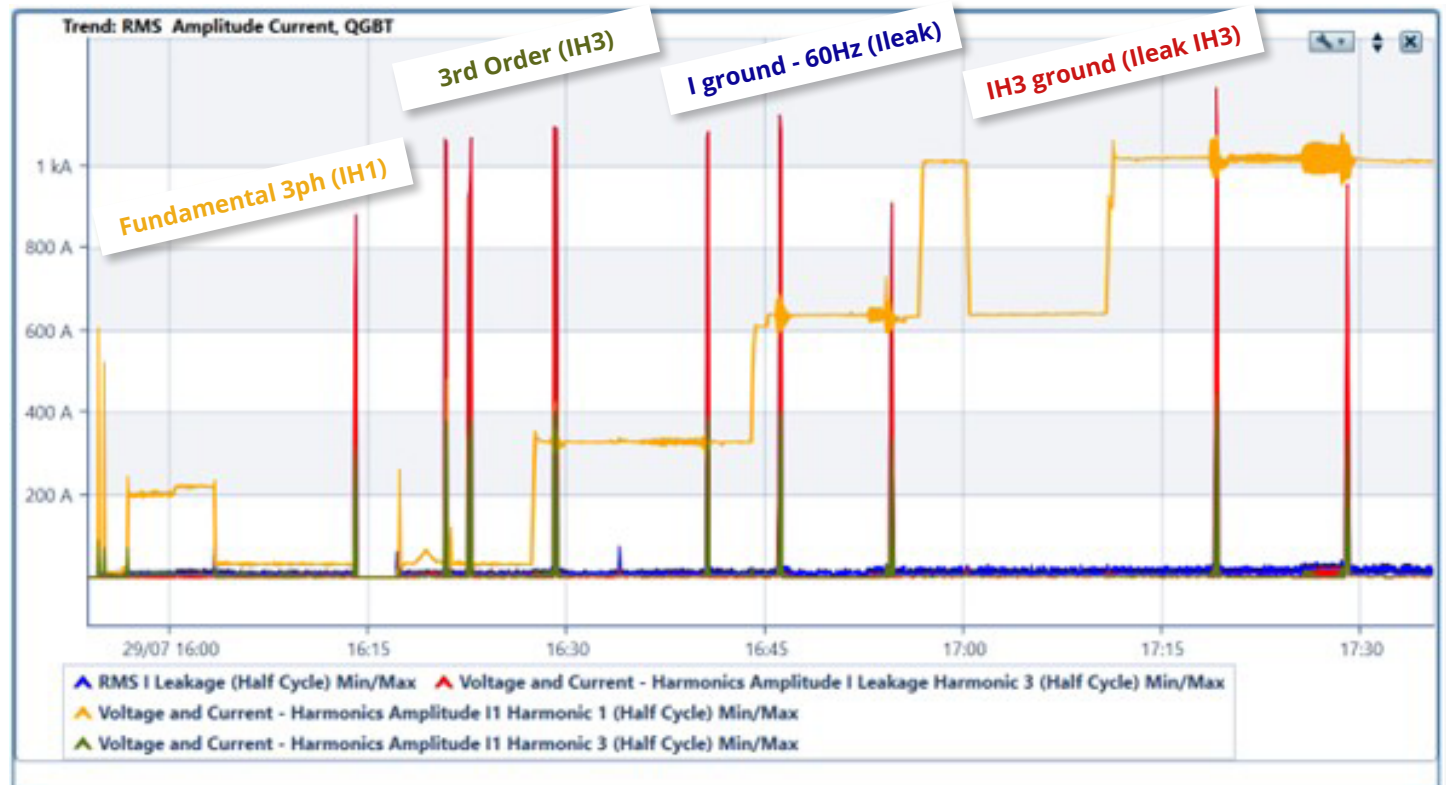

Load current - zoom in during voltage transient:

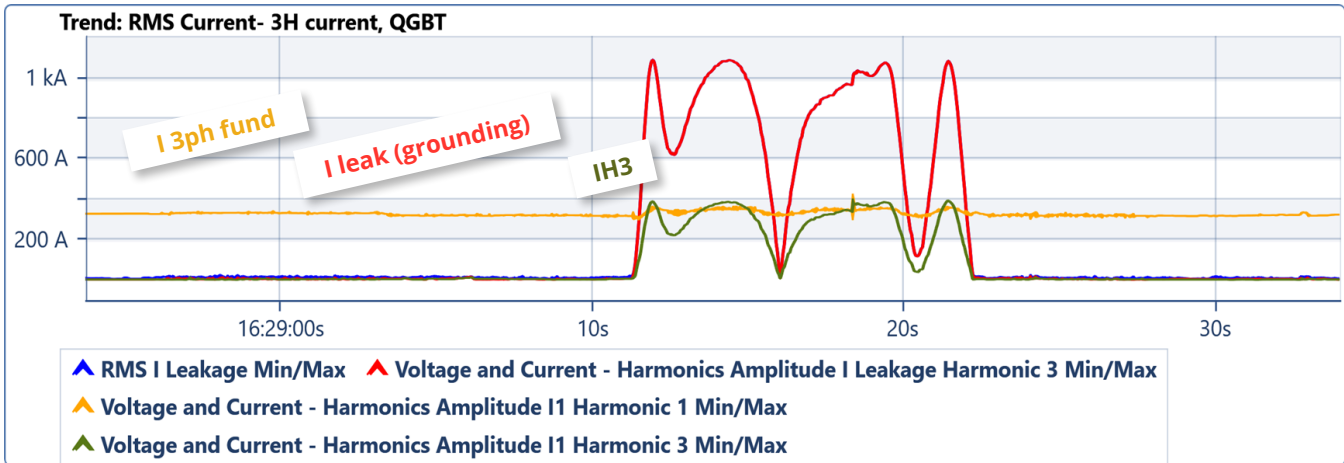
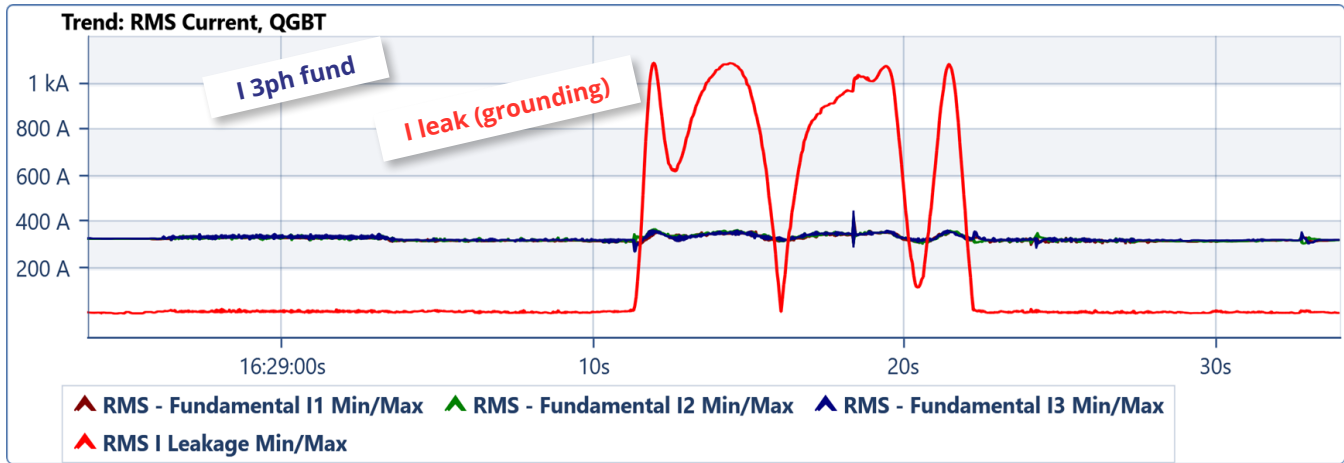

60Hz Current and leakage (grounding) current waveform

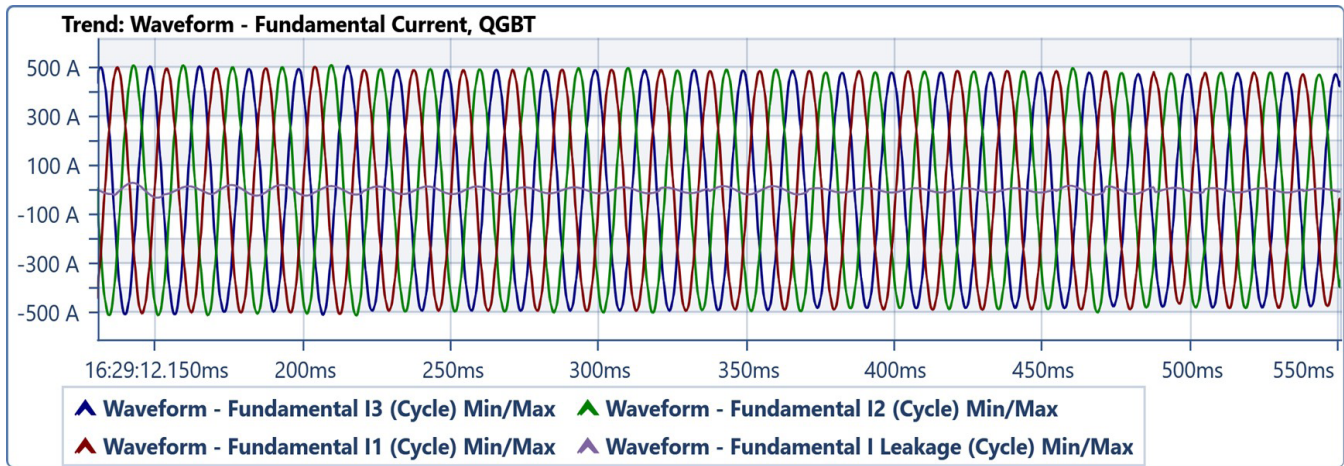

Harmonic current (IH) and leak (IHL-grounding) waveform:

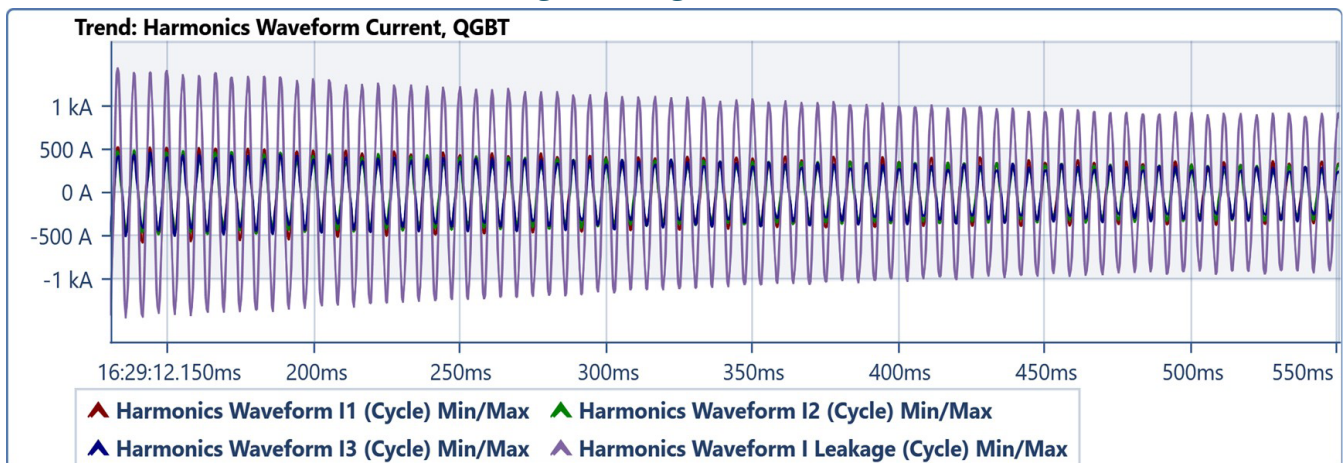

Root Cause

Triggered ground fault protection

The investigation revealed that the ground leakage protection (GS) system was tripping due to transient currents generated during the switching of synchronized power supplies, which included medium voltage (MV) utility company power systems and diesel generators. The transient currents, primarily consisting of 3rd order harmonic currents, were being read by the GS relay as fault conditions, causing system shutdowns.

The cause of these transients was traced back to the operation of the UPS rectifiers, which were equipped with IGBTs (Insulated Gate Bipolar Transistors). These rectifiers, designed to provide uninterruptible power, were generating unbalanced currents during the transition between power sources. As a result, the GS protection system, which is meant to safeguard against fault conditions, was interpreting these harmless transients as actual faults, leading to the trips.

Process

How the Problem Unfolded in the Data Center

The issue stemmed from the interaction between the synchronized switching of the power supplies, the transient currents produced by the UPS rectifiers, and the sensitivity of the ground fault protection system. The investigation, powered by Elspec's G4500 Power Quality Analyzer and PQSCADA Sapphire software, successfully identified the problem and provided actionable insights.

Conclusion

Addressing the Root Cause and Implementing Corrective Actions

The data center now has a clearer understanding of the underlying issue and can implement corrective measures, such as adjusting the ground fault protection system's sensitivity to 60HZ transient currents or incorporating new topology of grounding or filtering technologies to prevent misinterpretations during power supply transitions. This case highlights the critical role that advanced power quality monitoring and analysis tools like Elspec's solutions play in ensuring the stability and reliability of ground fault protection systems in data centers.



Ask us about our complete line of Power Quality Solutions www.quality-energy.com



Headquarters

Elspec Ltd.
info@elspec-ltd.com

North America

Quality Energy
info@quality-energy.com

Europe

Elspec Portugal Lda.
info@elspeceurope.com

India

Elspec Engineering India Pvt Ltd.
info@elspec.in

Región Andina

Elspec Andina
info@elspec.com.co