

QUALITY
ENERGY

ELSPEC
When Power Meets Quality

The BlackBox



Products
Catalog



Power Quality
Energy Saving
Solutions

Power Quality Solutions

Energy Saving Solutions	Page 2
Activar / Equalizer	Page 4
Equalizer ST	Page 12

Power Quality Metering & Monitoring



G4500/3500 Portable Power Quality Analyzers Blackbox	Page 19
G4K Fixed Power Quality Analyzer Blackbox	Page 24
Pure Single & 3 Phase Power Quality Analyzer Blackbox	Page 29
Digital Fault Recorder Phasor Measurement Unit BlackBox	Page 34
PQSCADA Power Quality Management Suite	Page 37

Energy Saving Solutions

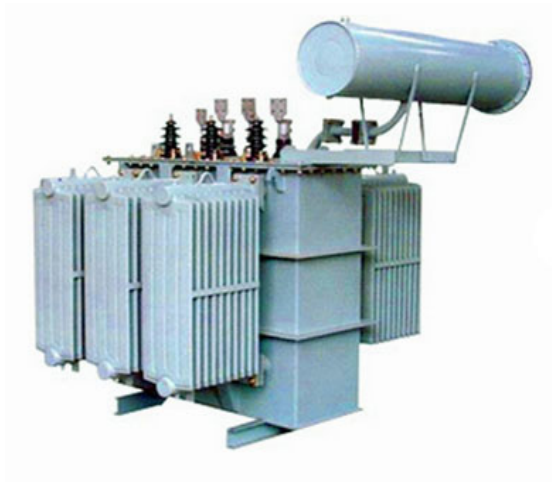

1. Voltage Optimization

Accurate control of Reactive Power consumption allows for the systematic controlled reduction of voltage and reduced energy use.

2. Current Reduction

Copper losses (I^2R) in transformers and feeders is minimized by the reduction of load current through the introduction of reactive power compensation.

3. Harmonics Reduction

Voltage and current Harmonic pollution can be reduced substantially using tuned filters for the 5th & or the 5th & 7th harmonic order.

The Power of Saving Money in 4 small stages

Substantial savings can be achieved when the following parameters of load exist:

- Continuous 24/7 plant operation
- Rapid load variation causing voltage fluctuation
- High or unstable voltage: can be reduced by one or two steps using transformer tap changer for voltage reduction options
- Medium to high level of harmonic pollution



Energy Saving Solutions

1

Measurements (Patented)

Using sophisticated advanced-Power Quality Analyzers measuring, recording and storing continuously at high resolution to Class-A standard.



2

Simulation Report (Patented based)

Sophisticated and Accurate report outlining energy savings and network benefits.

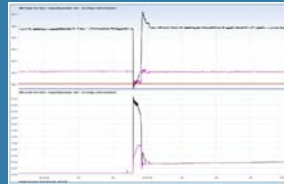

3

Solution

Equalizer



Current reduction
Harmonics reduction
Voltage stabilization

Transformer



Voltage reduction
by tapping down

4

Proof

Analysis of energy consumption before & after solution implementation.

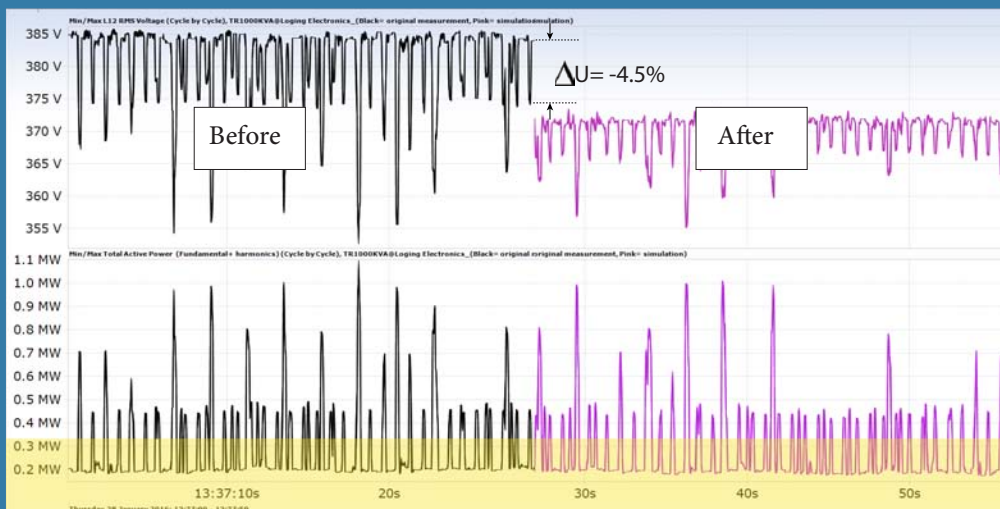

Zoom in ↓

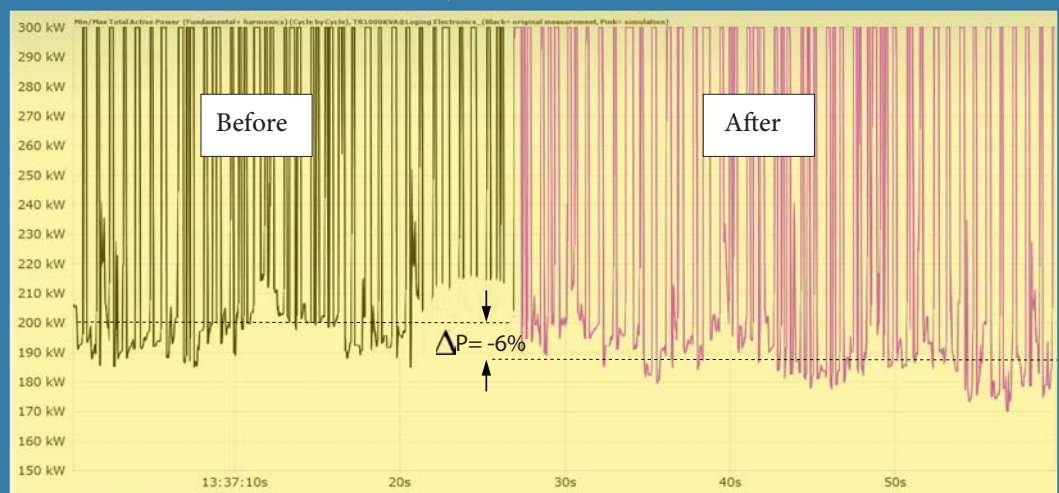

Equalizer Activar

The **Activar** is used for relatively stable loads such as commercial buildings, hospitals and data centers. The Activar is utilized for slow variations of reactive energy demand.



The **Equalizer** is used for dynamic loads such as plastic injection/extrusion, auto industries, motor startup, port cranes and more. The Equalizer is utilized for fast or extremely fast variations of reactive power demand. Also available: Equalizer single phase and dual phase.



While the structure of both systems is similar, the controllers are designed for real time controls and measurements for the Equalizer and slow response for the Activar . The following descriptions and explanations refer to the Equalizer System only.

Real time power quality enhancement system: Power factor correction, energy savings, voltage support, flicker reduction, current spike reduction, harmonic filtration and many other applications for a variety of dynamic loads

Equalizer Technology

Capacitor Group Switching

The equalizer switches capacitor groups on and off using state of the art electronic switches. The connection and disconnection of capacitors occur precisely at zero-current crossing. This smooth connection avoids transient effects typically created by electromechanically switched power factor correction (PFC) SYSTEMS, EXTENDING THE LIFE EXPECTANCY OF THE Equalizer dramatically

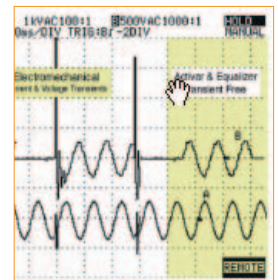
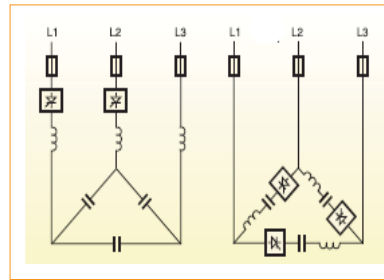

Consistent Capacity

Conventional electromechanical capacitor banks suffer from an ongoing cumulative deterioration in capacity due to transients during normal connection and disconnection. This can be especially detrimental in tuned and detuned electromechanically switched systems where changes in the ratio between the capacitors and reactors shift the resonant frequency. This scenario can provoke resonances, which could cause serious damages to the equipment . The equalizer is the solution. It enables a longer system life, lower maintenance costs and better consistency.

Fast and Accurate Measurements

The Equalizer controller uses FFT (Fast Fourier Transform) analysis in all phases of each cycle. Power information, system status and detailed logs of events are displayed on a large backlit graphic LCD screen, or via communication with the user-friendly PowerIQ software.

Ideal PFC Control

Using exclusive automatic control algorithms and rapid electronic switching, the total acquisition time (complete compensation of reactive current) is achieved in 2/3 cycle typical (1/4-1 cycle max.; 50Hz = 13.3 ms; 60 Hz = 11.1 ms), regardless the number of steps required.



Equalizer Activer

The Equalizer Power Quality Solution

Definition

Power quality is a term used to define any voltage, current or frequency deviation which may result in failed equipment, process interruptions or power system inefficiency. These deviations can manifest themselves in harmonics, power factor, voltage sags/swells, voltage flickering, transients and many other forms. The equalizer from Elspec is an all-in-one device designed to fix power quality issues. The equalizer is typically installed near the main service and major distribution panels.

Voltage Sags (voltage Drops, Under-Voltage)

Voltage sag, also known as voltage dips or under-voltage are mostly caused by local loads, either during motor startup or by rapid changing loads. This condition is characterized by low power factor and high reactive energy demand. The Elspec Equalizer's ultra-fast technology is designed to act in these specific conditions. It connects all required capacitor banks in 2/3 cycle typical (1/4 – 1 cycle max.), compensating for the total reactive energy of the event. Moreover, it changes the direction of the voltage drop vector to minimize the sag. As a result, the voltage sag is minimized and in many cases, even eliminated. (See motor startup notes on next page).

Voltage Flicker

Voltage Flicker is defined as fast, repetitive voltage fluctuation normally associated with rapid loads, such as spot welders. The Equalizer's control technology connects and disconnects all required capacitor banks in 2/3 cycle typical (1/4-1 cycle max.), allowing to effectively reduce the flicker to acceptable levels (See spot welding application note).

Power factor

In many cases, low power factors result in higher utility bills, penalties and increase in demand charges. They also cause system energy losses, overheating, higher maintenance costs

and low service utilization. The Elspec Equalizer is the foremost solution for dynamic low power factor correction. It eliminates utility penalties, contributes to saving energy and reduces maintenance costs, and also maximizes service utilization.

Harmonics (Non linear loads)

High harmonic voltages and currents cause significant energy losses and overheating. It could dramatically increase site vulnerability to failures or fire risk. More details on harmonics appear under the applications section on next page.

Spikes (Transients)

Spikes can generate significant damage to the equipment, and produce unpredicted power supply failures with a degradation of the capacitors. The equalizer solution uses transient-free switching technology to eliminate all spikes associated with conventional capacitor switching. The results are longer capacitor life expectancy, less maintenance and better network reliability

Service Utilization

Higher service utilization is a constant wish of all electricity users, whether the power is provided by the utility, generators or other local generation such as wind turbines. By using the equalizer the existing service utilization may dramatically increase by reducing the average current and stabilizing current fluctuations. Existing installations show service utilization increases of up to 60% (See Generator application note).

Voltage Control

In addition to power factor and other power quality issues, there is sometimes a need to maintain voltage levels within certain limits due to sensitive equipment or other facility requirements. The Equalizer voltage control option offers 6 different voltage control levels. The voltage control operates in parallel with the power factor control and in fact, complements it.

Power Factor Compensation – A comparison

The Equalizer is an ideal solution for power quality applications. Regardless of the application, the equalizer solution achieves near-perfect power factor control, network stabilization and energy savings. In many cases, the equalizer is the only proper solution: Implementing slow –response power factor compensation or even quasi-real-time systems in these applications would actually reduce power quality and possibly produce wasted energy. The following example compares the results of the Equalizer (2/3 cycle typical, 1/4-1 cycle max.) with a quasi-real time solution (1 step/3 cycles):

Correct compensation using the Equalizer

Graph A demonstrates the Equalizer's compensation of the reactive current in a 14- cycle energy load. Typical acquisition time (full compensation of reactive current) is less than once cycle and total current is substantially reduced.

Incorrect compensation using slow response systems

Graph B demonstrates incorrect compensation where response time is 3 cycles to connect a single group and acquisition time required to connect a total of 4 groups is 12 loads. Due to the delay in connections, the current is only partially reduced. Further, the corresponding delay in disconnection causes residual current. The overall effect of this compensation system on total current is negative, as the average current of the load is increased, rather than decreased. This phenomenon will increase voltage flickering due to overcompensations.

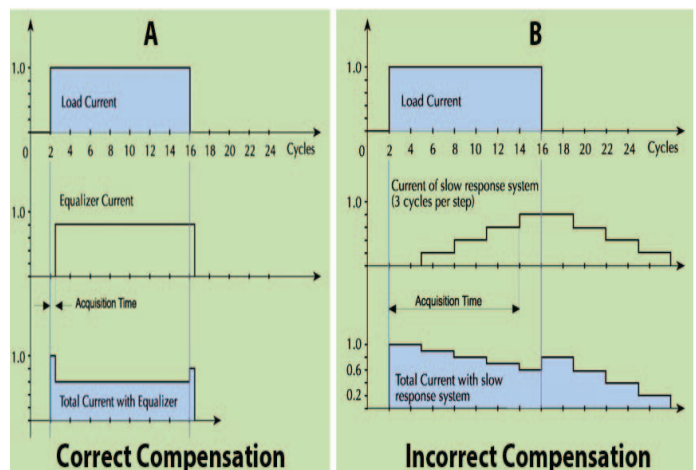

Equalizer Activer

Applications

Welding machines

Spot welding loads fluctuate extremely rapidly and consume a large amount of reactive power. Due to high current changes generated by the near-instantaneous reactive energy consumption, large voltage drops are produced. These sags reduce welding quality and productivity. Additionally, these loads often create a high incidence of voltage flickering, which frequently exceeds recommended IEEE limits.

Plastic injection Molding

Due to widely varying unsynchronized load conditions, plastic injection molding applications have rapid and inconsistent reactive energy requirements. Power supply failure during a production cycle can cause enormous financial and physical damage caused by plastic cooling inside the machines. Besides reducing overall system energy losses, Elspec's Equalizer solution can drastically reduce the risk for such an event by stabilizing the current and voltage levels in the facility on a cycle by cycle basis.

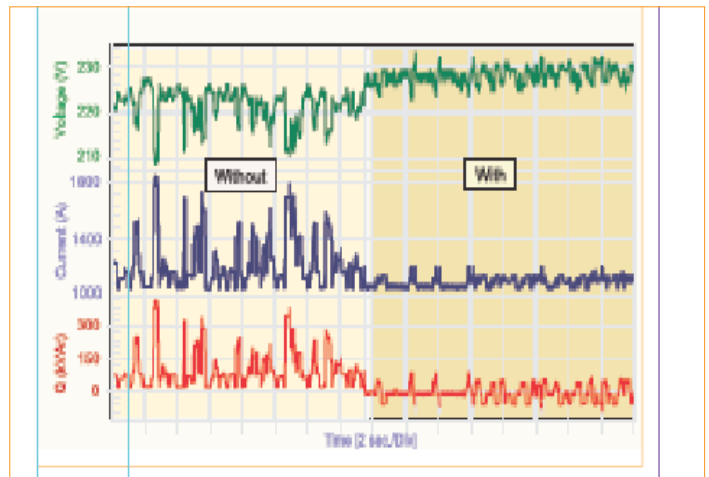
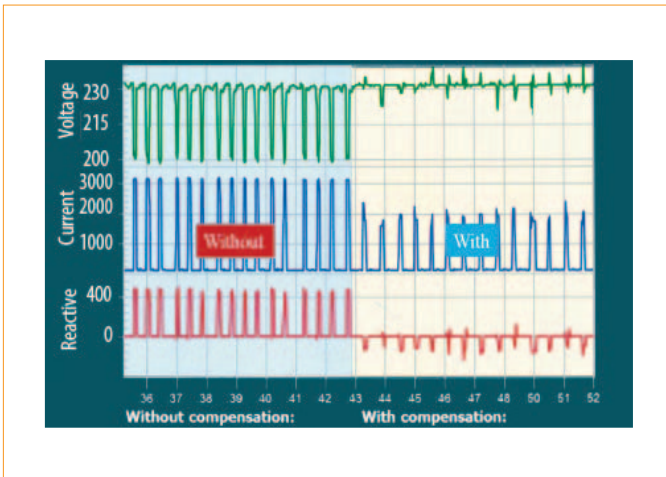

Harbor Cranes

The complete operation cycle of harbor cranes is approximately one minute. During this time, the crane requires variable amounts of reactive energy, fluctuating rapidly throughout the entire crane cycle. The Elspec Equalizer's real time solution enables:

- To stabilize the voltage
- To reduce current
- To enhance lifting capacity

Motor Startup

When connected directly to the line, large squirrel-case inductive motors consume very high current during the start-up period (six times higher than steady state operation). This high current consumption can lead to significant voltage drops on both -low and high- voltage sides of the transformer. This phenomenon interferes with other loads, reduces initial torque and increases start-up time. The equalizer system tracks the reactive current and fully compensates it in 2/3 cycle typical (1/4 - 1 cycle max.), offering the following benefits:

- Protection against voltage drop on the main service
- Capability to central start all loads, avoiding the use of individual starters commonly used to protect against voltage drops
- Direct connection of motors to main service, obtaining maximum torque during startups. This benefit is unique to the Equalizer solution. Starters of all types typically reduce the current going to the motor, thereby reducing the starting torque

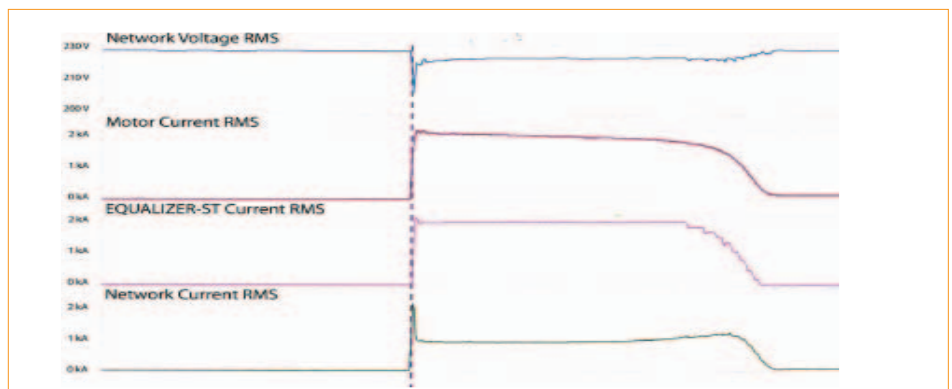

Equalizer Activar

Detuned Equalizer (Resonance Prevention)

Utilities generate an almost perfect sinusoidal voltage. Harmonics, created by nonlinear loads such as variable speed drives, power rectifiers, inverters etc. These loads cause nonlinear voltage drops and change the sinusoidal nature of the voltage.

When reactive energy is compensated using capacitors, there is a frequency at which the capacitors are in parallel resonance with the power source (high impedance). If the resonant frequency occurs in proximity to one of the harmonic sources, current could circulate between the supply and the capacitors, resulting in high voltage on the line. In this scenario, current levels may exceed the capacitors rated current by more than two or three times, and can cause a transformer burn.

Resonance may occur on any frequency; however in most cases, current harmonic sources exist at the 5th, 7th, 11th and 13th harmonic. The Equalizer's custom-designed reactors, used in series with the capacitors, prevent resonance by shifting the capacitor/network resonance frequency below the first dominant harmonic (usually the 5th).

Tuned Equalizer (Harmonics Filtration)

Harmonics current can be substantially reduced by using harmonic filter. A filter consists of a capacitor in series with a reactor tuned to a frequency which is at the vicinity of the harmonic source (5%-10% lower). The impedance of the filter is very low at the harmonic source and therefore most of the harmonic current flows to the filter. This way, the harmonic source doesn't flow to the direction of the power source (transformer) and as a result, the voltage is not distorted.

Elspec offers either harmonic filter for the 5th harmonic or filter for the 5th & 7th (in case the 7th is also dominant).

The capacitor and the reactor parameters are carefully designed in order to cope with over current & voltage caused by the harmonics.

The filter can be designed to absorb approximately 80% of the relevant harmonics.

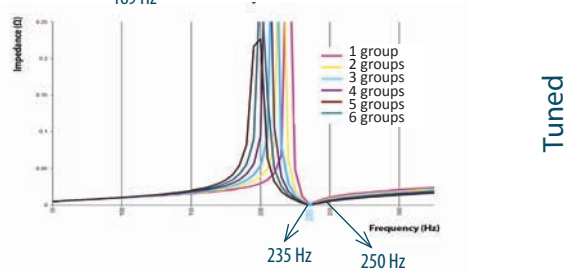
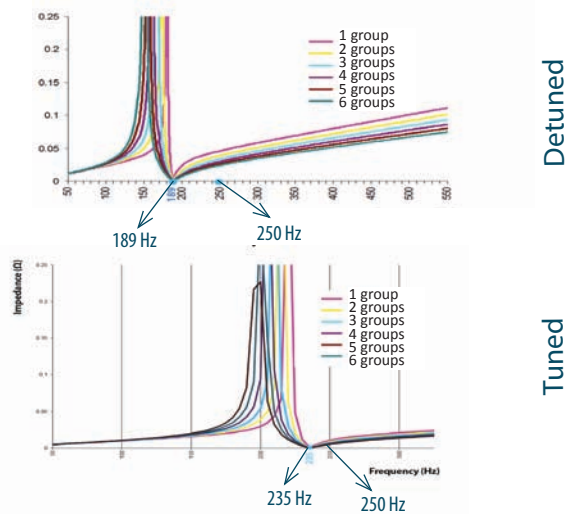
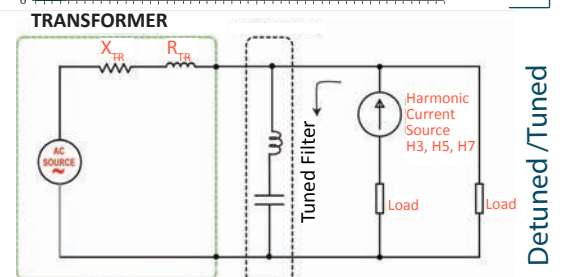
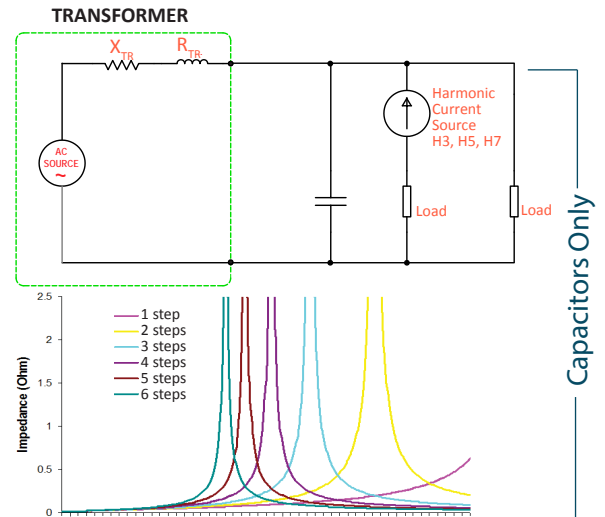

Generators (emergency stand by, parallel and stand-alone operation)

The use of generators of local power generation for normal facility operations and emergency back-up has become much more prevalent in recent years. All types of generators can benefit from power factor compensation provided by the Equalizer. The Elspec Equalizer:

- Increases useable power
- Allows separate target power factor programming, dependent on generator operational mode, when specified with generator option
- Potentially increases financial savings when multiple generator system are used in tandem
- Enables downsizing of new generator installations.

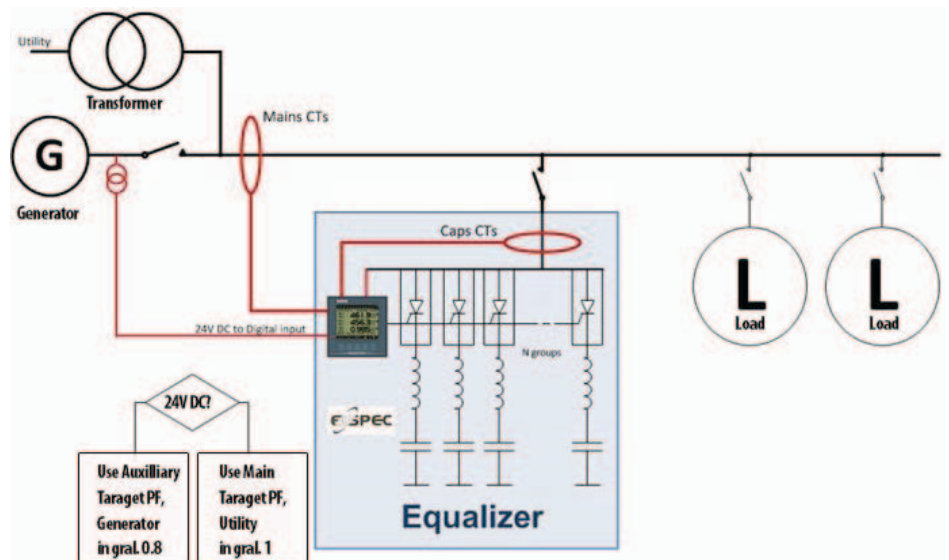

Equalizer Activer

System Structure

Switching module

The switching module is comprised of solid-state switching elements that provide reliable, high-speed transient-free operation. Single, double or three-phase electronic switches, SCR/SCR or SCR/diode, are used for each capacitor group. Switching modules are specifically selected for each equalizer system based on the number of overall capacitor groups, current requirements and voltage rating.

Cabinet Design

Each equalizer system IP20/NEMA1 cabinet is made of steel sheet, with an epoxy powder coated gray (RAL 7032).

Cabinet Options

- Protection class upgrades (IP/NEMA)
- Top-mounted fan unit and filters
- Lockable fuse indication
- Magnetic door lock
- Top cable supports
- Lifting eyes bolts
- Pad-lock entry

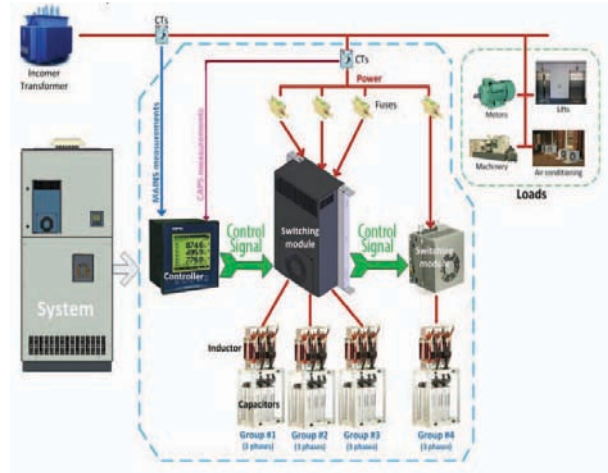

The Controller

A digital signal processor (DSP) component is the basis of the controller's technology. The controller features a LCD display, analog and digital circuitry, precise firing algorithms and optional communication capabilities. The controller counts 9 input channels: 4 voltages (for Wye networks), 3 main currents and 2 internal system currents. The information obtained from these measurements is used for Fast Fourier Transform (FFT) analysis, performed each network cycle on all channels. The advanced control algorithm, supported by unique patent-pending technology for fast compensation, calculates the required compensation in 1 ms. Further, harmonics are calculated on all phases, allowing the EQUALIZER to achieve ideal compensation even in the presence of harmonics.

The EQUALIZER's controller is available with a choice of data gathering levels, from essential power parameter measurements (V, I, f, Kw, kVA, kVAR) to a complete power system performance monitoring capable of taking advantage of the comprehensive measurement system (over 2,000 electrical parameters, including min/max levels and four-quadrant measurement of power and power factor).

The large LCD display is a full-graphic, 160x128 pixels screen, with a long-lasting LED backlighting with FSTN technology. Characters are displayed in varying sizes and methods to enhance visibility. These include a large digits display, harmonic spectrums, real-time waveform plots and simple text screens including menus, easy-to-use setup programs and various measurements.

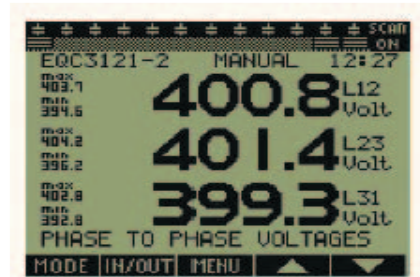

Optional



PQSCADA Sapphire allows all Fault Recorders, Power Quality Analyzers, Revenue Meters and all other IED to be analyzed in one system. Learn more about PQSCADA Sapphire on page 37



The BlackBox G4400 series is equipped with the revolutionary PQZIP patent algorithm for continuous waveform recording. Learn more on page 22

Equalizer Activar

Capacitor/Reactor Modules

Iron Core Reactors

Each Elspec equalizer includes high quality iron core reactors used in series with the capacitors. Each reactor is manufactured under tight control tolerance to ensure quality. It is built with a laminated, low-hysteresis loss iron core, copper windings, precision-controlled air gaps and class H insulation (180°C).

Available reactor types:

Inrush-only: Reactors are designed to limit the inrush current which may develop in the capacitor during power up, preventing thereby any damage to the switching elements, fuses and capacitors

De-tuned: Prevent resonance condition by shifting the capacitor/network resonant frequency to below the first dominant harmonic (usually the 5th)

Tuned: Designed to absorb a majority of the dominant harmonic(s), usually the 5th or the 5th and 7th.

Capacitors

Elspec equalizer features MKP-type capacitors that are low-loss (0.25W/kVAr) and housed in a cylindrical aluminum casing. The MKP-type capacitor is a metallized polypropylene film capacitor featuring self-healing properties and an overpressure tear-off fuse. To reduce the effects of electrical and thermal overload and extend operation life expectancy, the capacitors are connected during zero-current crossing and operated in a time-sharing mode (SCAN).

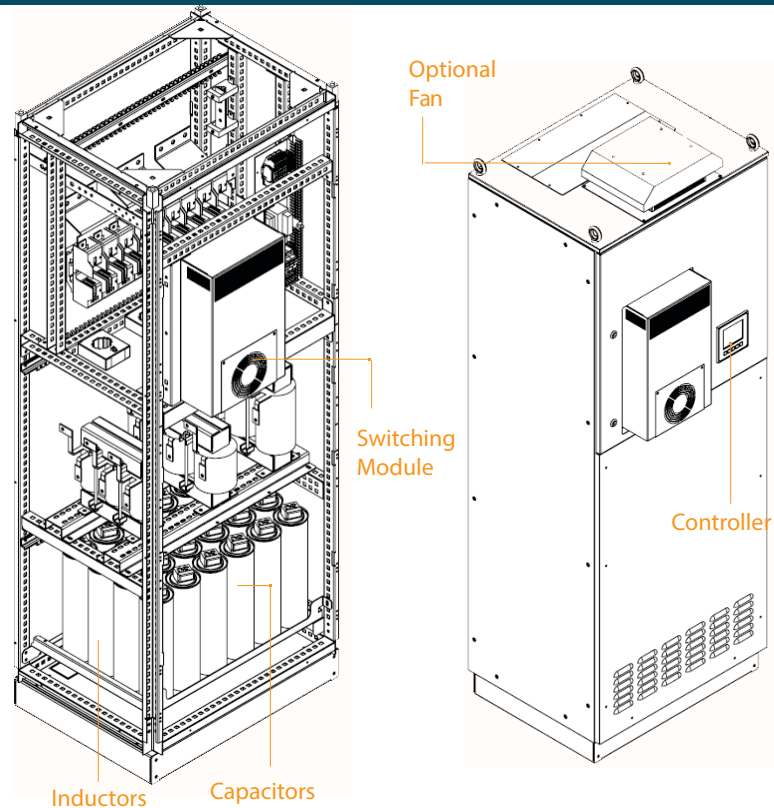

U - Unbalanced system for three-phase networks with single-phase capacitors

S - Single phase system for single-phase networks with single-phase capacitors

W - Wind Energy, a version specifically designed for wind turbine generator applications

V - Voltage control, where the controller connects or or disconnects steps according to user-defined voltage limits (6-level)

T - Medium Voltage compensation, use LV capacitors and step-down transformer

M- Medium Voltage compensation, using MV capacitors (see type T)

G-Generator applications, allows two power factor targets dependent on generator mode of operation

P – External trigger signal for synchronized compensation, allowing instantaneous compensation (0ms)

Specifications

Rated Voltage:

Low voltage systems:

220V – 690 V

50 or 60 Hz

Single phase or three-phase

Medium voltage systems:

Up to 69 kV

50 or 60 Hz

Ambient Temperature Limits:

+ 40°C: max (< 8 hours)

+ 35°C: max 24h average

+ 20°C: yearly average

- 10°C: minimum

Capacitors:

Low loss, self-healing, IEC 831-1/2

Protection class:

IP 20 / NEMA 1 (Other on request)

Controller Display:

5" Graphic LCD

160*128 pixels

High visibility (FSTN)

Durable LED Backlight

Design:

Steel sheet cabinet

Enclosure Finish:

Epoxy powder coated

Gray (RAL 7032)

Internal parts:

Rust-proof alu-zinc

ENC Standards:

EN 50081-2

EN 50052-2

EN 55011

EN 61000-4-2/3/4/5

ENV 50204

ENV 50141

Safety Standards:

ENA 61010-1

ENA 60439-1

UL 508 (upon request)

Complete system ordering information

System Type	Total Power	Step Size	No. of Groups	Nominal Voltage	Nominal Frequency	Reactor %	Network Typology	Group Protection	Cable Connection	Cable Entry
EQ	1440	:120	:12	-400	50	P7	W	F	C	A

System type	EQ	Equalizer complete system
Total Power		Total power in KvaR
Step size		Step size in KvaR (Switching Resolution)
No. of Groups		(No. of groups (Physical, max. 12)
Nominal Voltage		Nominal Phase to phase Voltage in volts
Nominal Frequency		(Nominal Frequency in Hz (50 or 60 Hz
Reactor Percentage	PO and P#	Inrush limiting reactors only Percent of capacity. Example: P7= 7%
Network typology	D W V	Delta 3 wires Wye 4 wires Wye 3 wires
Group Protection	F M	Groups protected by fuses Groups protected by MCCBs
Cable connection	C S M	Single point with integral circuit breaker Single connection point Multiple connection points
Cable Entry	T B A L R	Top cable entry Bottom cable entry Top and bottom cable entry Left side cable entry Right side cable entry

Controller ordering information

Controller Type	Measurement Level	No. of Groups	Comm. Card	Power Supply	Special Type
EQC	3	12	2	2	WT

Controller Type	EQC	Equalizer controller
Measurement level	2 3	
No. of groups		Number of groups
Comm. Card	0 1 2	No. communication RS 485 ELCOM Protocol RS 485 ELCOM and MODBUS/RTU Prtocols
Power supply	1 2	115v 230V
Special type		See Controller section on previous pages Up to two types can be combined

Example: EQ 300:60:3-400.50-P7-WFSA
300kVA real time complete Equalizer system with
5 steps of 60 kVA with 7% inductors for 400V/50Hz
4-wires Wye network.
Dimensions (W* D* H*): 800*600*2100, Short circuit
35kA, IP 20

Controller ordering information

Parameter	Phases	Loads	Measurement Levels	
			2	3
Frequency	Common	Mains	X	X
Phase Current	L1, L2, L3	Mains, Load, Cap	X	X
Neutral current	Neutral	Mains	X	X
Phase to Phase current*	L1-2, L2-3, L3-1	Mains, Load	X	X
Phase voltage	L1, L2, L3	Mains	X	X
Neutral Voltage	Neutral	Mains	X	X
Phase to phase voltage	L1-2, L2-3, L3-1	Mains	X	X
Active Power (kW)	L1, L2, L3, Total	Mains	X	X
Reactive Power (Lvar)	L1, L2, L3, Total	Mains, Load, Cap.	X	X
Apparent Power (kVA)	L1, L2, L3, Total	Mains, Load, Cap.	X	X
Power factor	L1, L2, L3, Total	Mains, Load, Cap.	X	X
Time of use (TOU)-in, out, net, total				
Active Energy (kWh)	Total	Mains	X	X
Reactive Energy (kVARh)	Total	Mains	X	X
THD at Phase Current	L1, L2, L3	Mains, Load, Cap	X	X
THD at Neutral Current	Neutral	Mains	X	X
THD at Phase to phase current	L1-2, L2-3, L3-1	Mains, Load	X	X
THD at Phase Voltage	L1, L2, L3	Mains	X	X
THD at Neutral Voltage	Neutral	Mains	X	X
THD at phase to phase voltage	L1-2, L2-3, L3-1	Mains	X	X
Harmonics of Phase current	L1, L2, L3	Mains, Load, Cap.		X
Harmonics of Neutral current	Neutral	Mains		X
Harmonics of Phase to phase current	L1-2, L2-3, L3-1	Mains, Load		X
Harmonics of phase voltage	L1, L2, L3	Mains		X
Harmonics of Neutral Voltage	Neutral	Mains		X
Harmonics of Phase to phase Voltage	L1-2, L2-3, L3-1	Mains		X
Waveforms of Phase current	L1, L2, L3	Mains, Load, Cap		X
Waveforms of Neutral current	Neutral	Mains		X
Waveforms of Phase to phase current	L1-2, L2-3, L3-1	Mains		X
Waveforms of phase voltage	L1, L2, L3	Mains		X
Waveforms of Neutral Voltage	Neutral	Mains		X
Waveforms of Phase to phase Voltage	L1-2, L2-3, L3-1	Mains		X
System Log			X	X
Event log			X	X

*Unique feature: metering internal current of feeder transformer (delta secondary)

Equalizer- ST

MEDIUM AND LOW VOLTAGE MOTOR STARTUP SOLUTION

System Overview

The EQUALIZER – ST is a real-time dynamic power compensation system that utilizes a proven industrial technology to provide an additional solution for the challenges related to large motor startups. The system itself operates at a low voltage and by utilizing a step-up transformer, the **EQUALIZER – ST** is also able to compensate medium voltage networks.

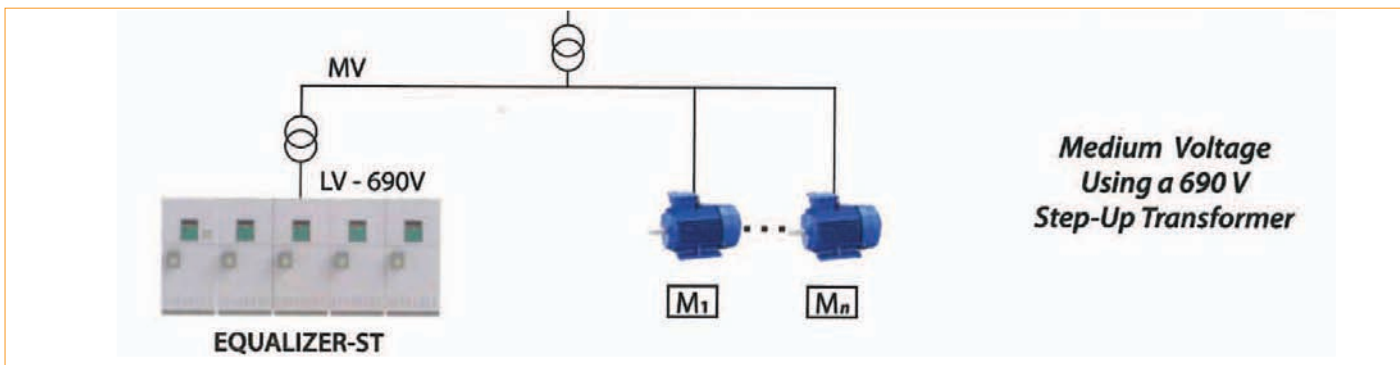
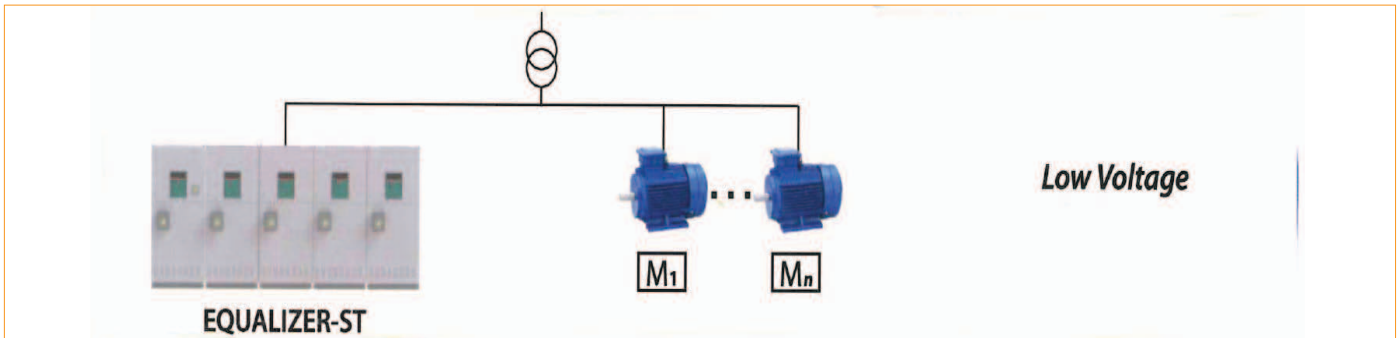

The Electrical Challenge

A motor start demands very high power for a relatively short period of time.

The starting current of an AC motor usually varies from 6 to 8 times the nominal current. This is due to the large amount of energy that is required to magnetize the motor, enough to overcome the inertia system has at standstill. The high current draw from the network usually causes problems such as voltage drop, high transients and, in some cases, uncontrolled shutdowns. The graph below demonstrates a typical startup phenomena for a 500KW motor, with a power factor of 0.89:

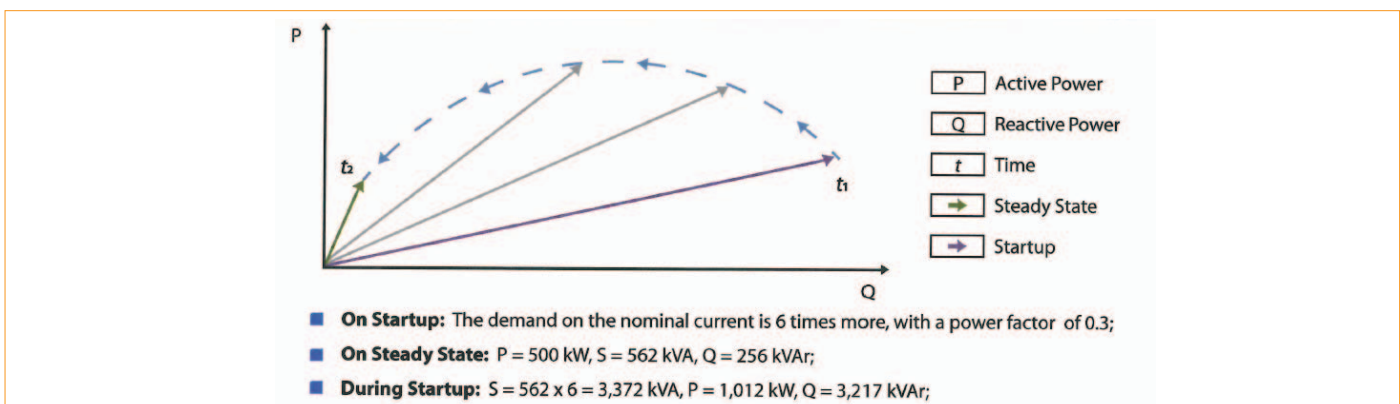

Centralized Motor Start-up Compensation

The EQUALIZER – ST is a centralized motor startup solution, that provides fast compensation in real-time. In an environment of many motors, one EQUALIZER – ST system serves any number of motors, assuming that two motors are not started simultaneously. By eliminating the need to use individual soft start devices for each motor, it makes the EQUALIZER – ST more cost effective than any other conventional compensation systems.

Equalizer- ST

Mitigating Voltage Sags

The most common cause of over currents leading to voltage sags are motor startup. One of the main design features of the EQUALIZER – ST is the ability to mitigate voltage sags during motor startup operations. As demonstrated in the diagram below, it is able to do so by injecting reactive power, for the given voltage sag magnitude at the required compensation period. This diagram includes a transformer [T] its impedance [X_{LT}, R_{LT}], an additional line [X_L, R_L] the EQUALIZER – ST [X_C] and the load [R_{LOAD}, X_{LOAD}].

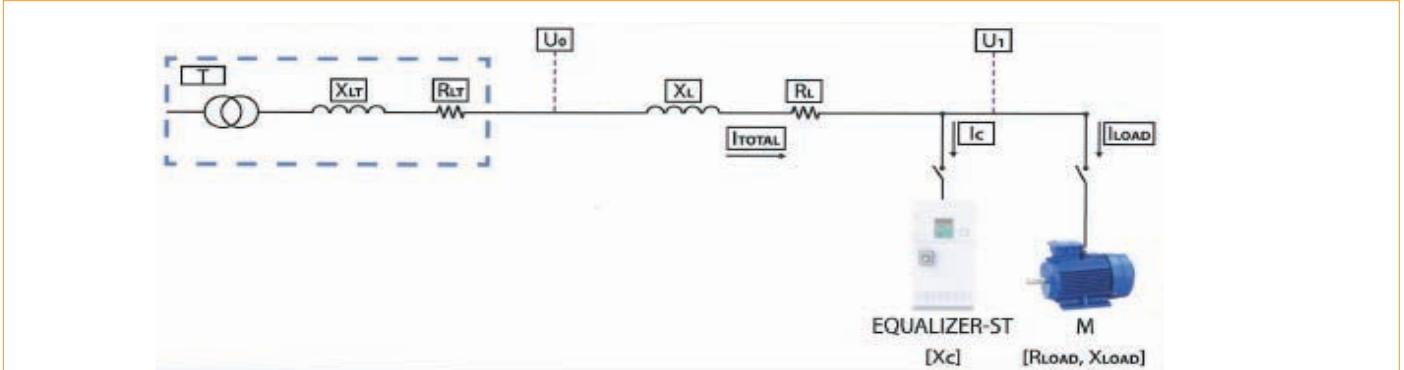

During a voltage sag the source input [U_o] drops to a substantial lower level – U_1 .

As soon as the voltage sag starts, the EQUALIZER – ST immediately connects in order to create total leading current [Red]. Once it is connected the voltage drop on the resistive part is synchronized with a total current, shifting in a counter-clockwise [opposite] direction. Subsequently, the voltage drop on the inductive part also shifts to 90° , resulting in a substantially lower U_o .

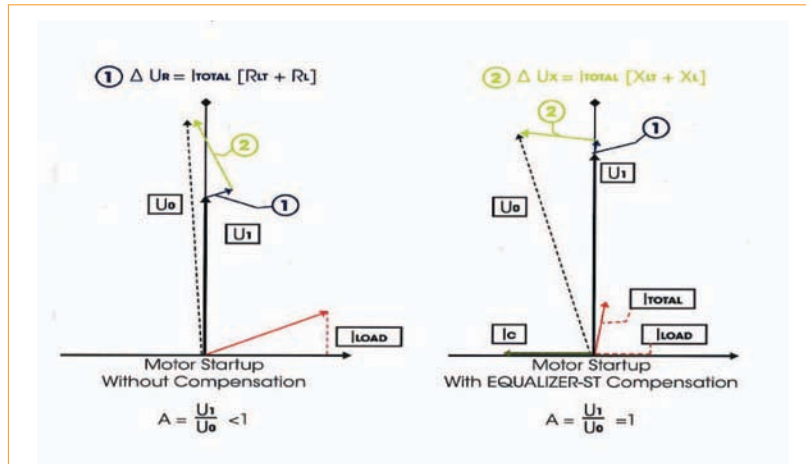

Optimizing Network Power Quality and System Performance

The EQUALIZER – ST minimizes the motor's startup period, thereby avoiding unnecessary wear to the motor and simultaneously extending the motor's life expectancy. The system also improves the overall power quality of the network, by reducing harmonic levels and introducing transient-free switching. It also significantly reduces the startup current, thereby securing a safe and successful startup of the motor.



Water pump station at Mekorot Israel



EQ-ST at Mekorot with 7 MVar

Equalizer- ST

Specifications

Low voltage system which is designed to control the reactive energy at MV using a boosting transformer*	Primary: Up to 66kV Secondary: 690 V (typically)	
Start up time	Up to 30 seconds	
Duty cycle	5%	
Ambient temperature limits	-10°C up to 40°C	
Capacitors	Low loss, self healing IEC 831-1/2	
Protection class	IP 20/NEMA 1 (others upon request)	
Design	Sheet steel cabinet	
Enclosure finish	Epoxy powder coated gray (RAL 7032)	
Internal Parts	Rust proof alu-zinc	
EMC standards	EN 50081-2 EN 50082-2 EN 55011	EN 61000-4-2/3/4/5 ENV 50204 ENV 50141
Safety standards	EN 61010-1 EN 60439	

The system can be used without a boosting transformer for networks up to 690 V(480 V, 400 V, etc.)

Cabinets

	Low Voltage 400 V	Medium Voltage 690 V
Reactive Power (kVAr)	Up to 670 kVAr per cabinet	Up to 1400 kVAr per cabinet
Dimension (H x W x D) cm	210 x 100 x 80	
Number of cabinets (STEPS) per system: Up to 12		

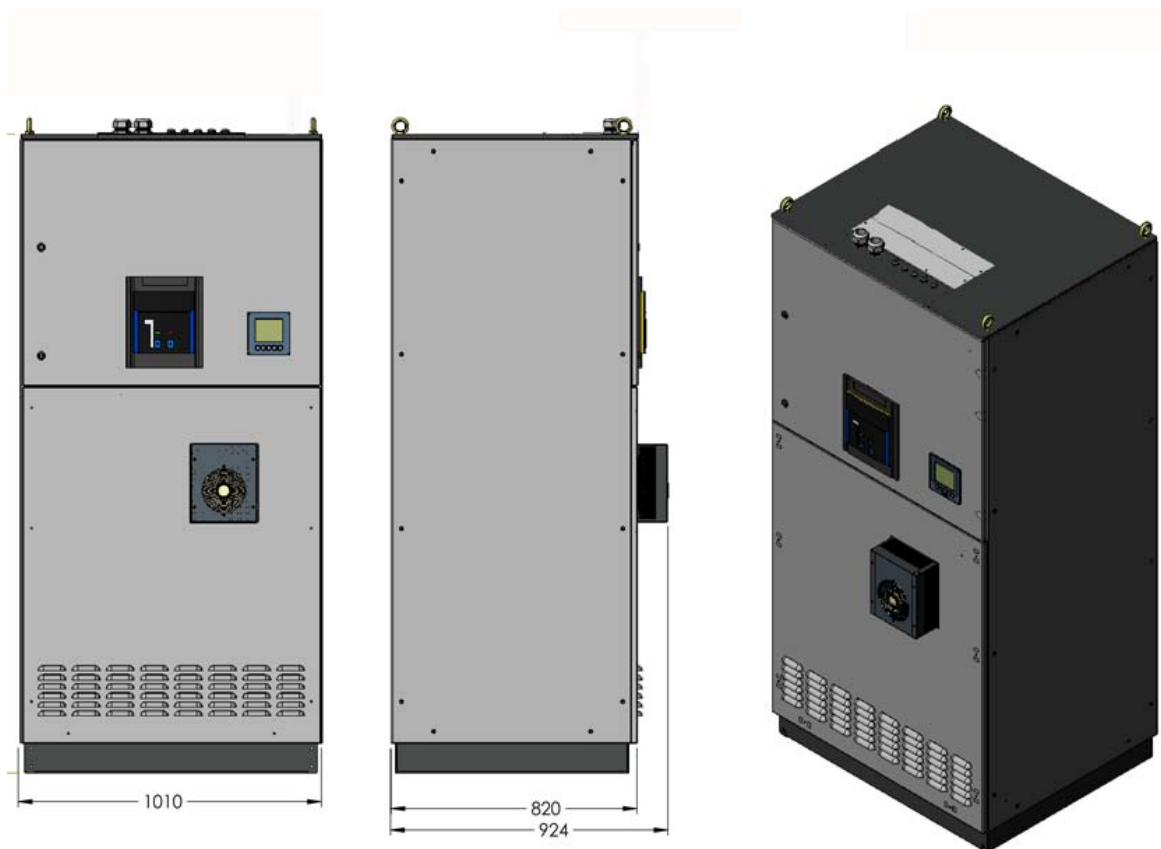

Equalizer- ST

EQUALIZER – ST Low Voltage– 176 kW Motor Startup

Actual Measurement Data without Compensation

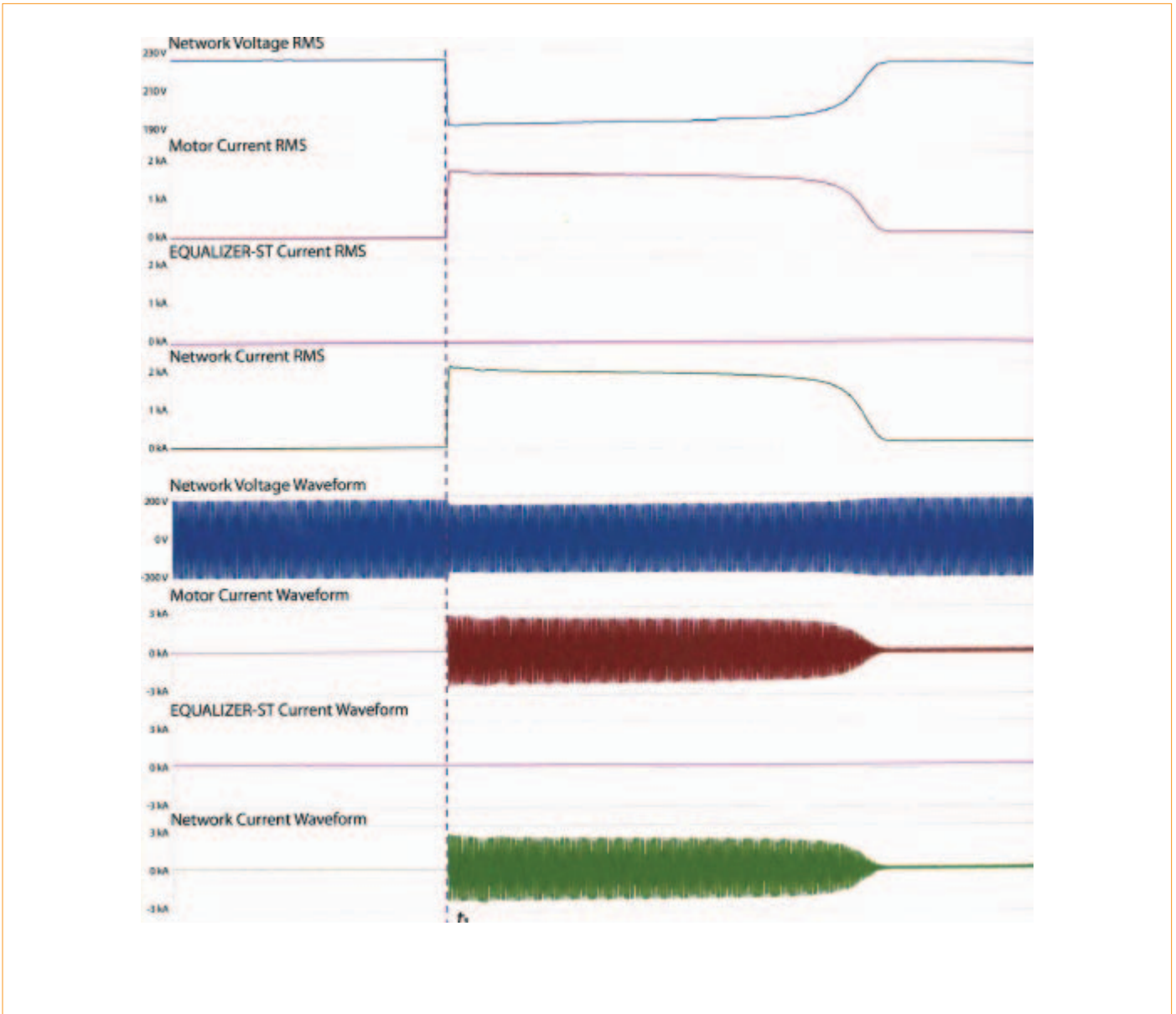

Measured Values Without & With Compensation:

Parameters	Without Compensation	With Compensation	Improvement
Total voltage sag during start-up AU %	-14%	-2%	85%
Current during startup	1600 Amp	600 mp	61%
Startup duration	5.4 sec	3.8 sec	30%

Equalizer- ST

Actual Measurement Data with EQUALIZER – ST Compensation

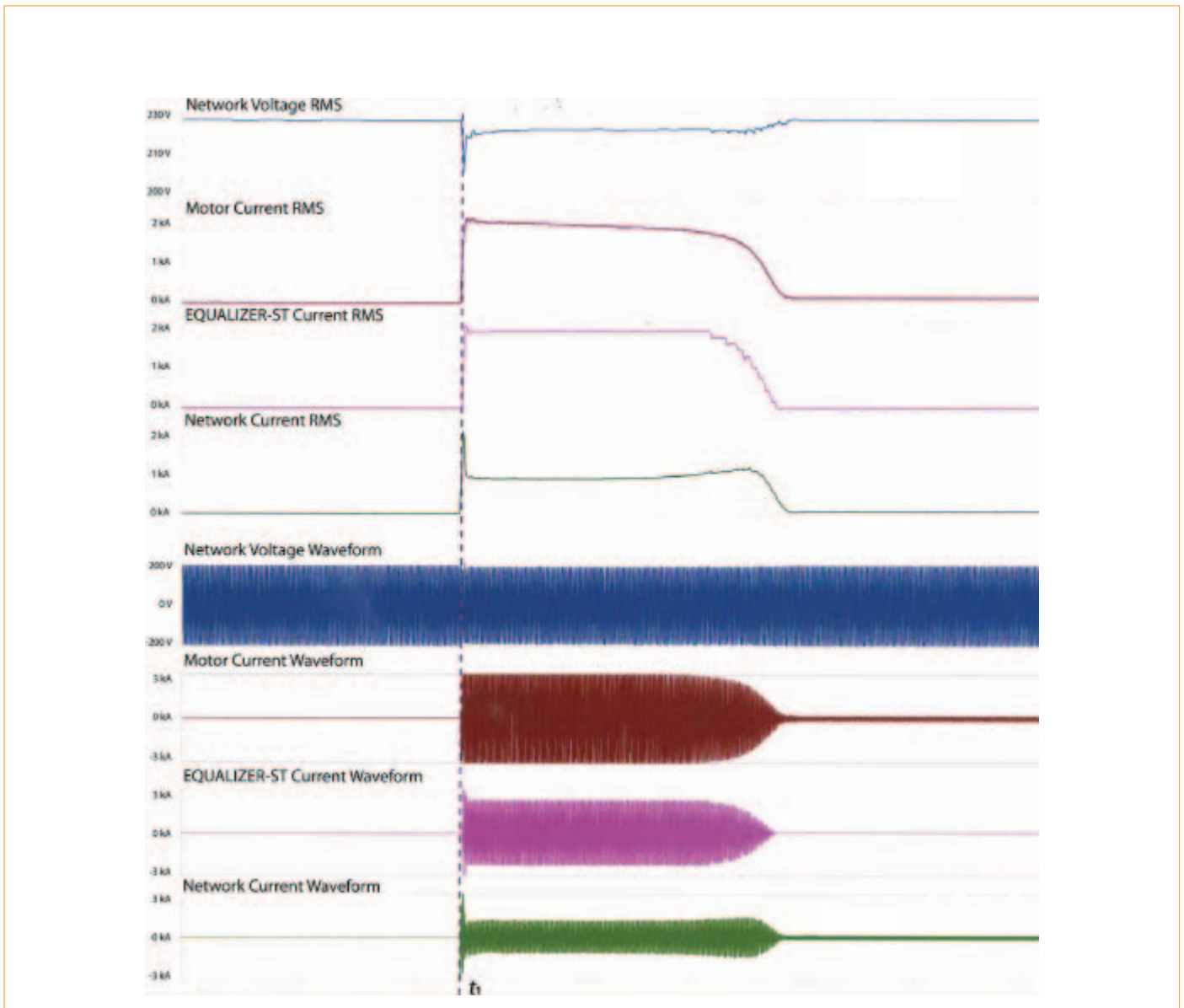

Zoom-In EQUALIZER – ST Step by Step Compensation

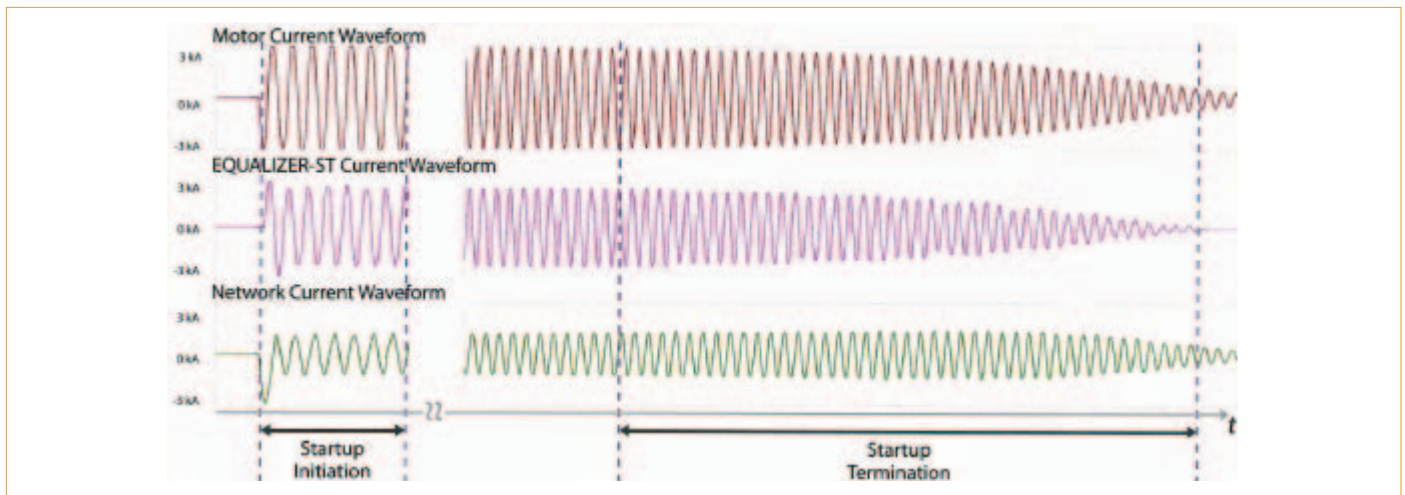

Equalizer- ST

EQUALIZER – ST Medium Voltage– 176 kW Motor Start-up

Actual Measurement Data without Compensation- 11kV Networks

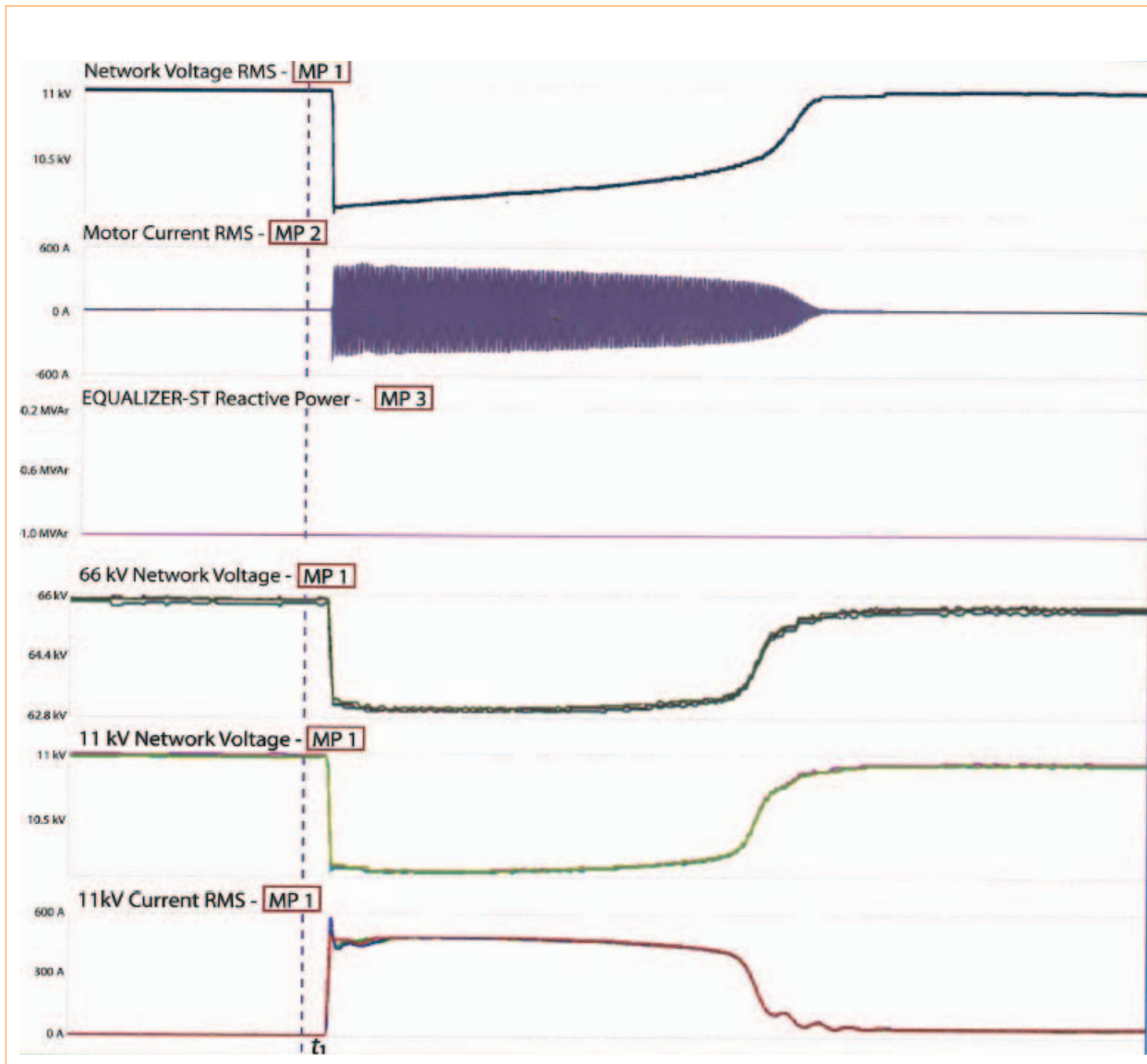

Actual Water Pump

Measured Values Without & With Compensation

Parameters	Without Compensation	With Compensation	Improvement
Total voltage sag during start-up at 66 kV AU %	-4.1%	-1.42%	65%
Total voltage sag during start-up at 11 kV AU %	-8.8%	-2.8%	68%
Total current at 11kV	580 Amp	280 Amp	51%

Equalizer- ST

Actual Measurement Data with EQUALIZER – ST Compensation – 11 kV & 66 kV Networks

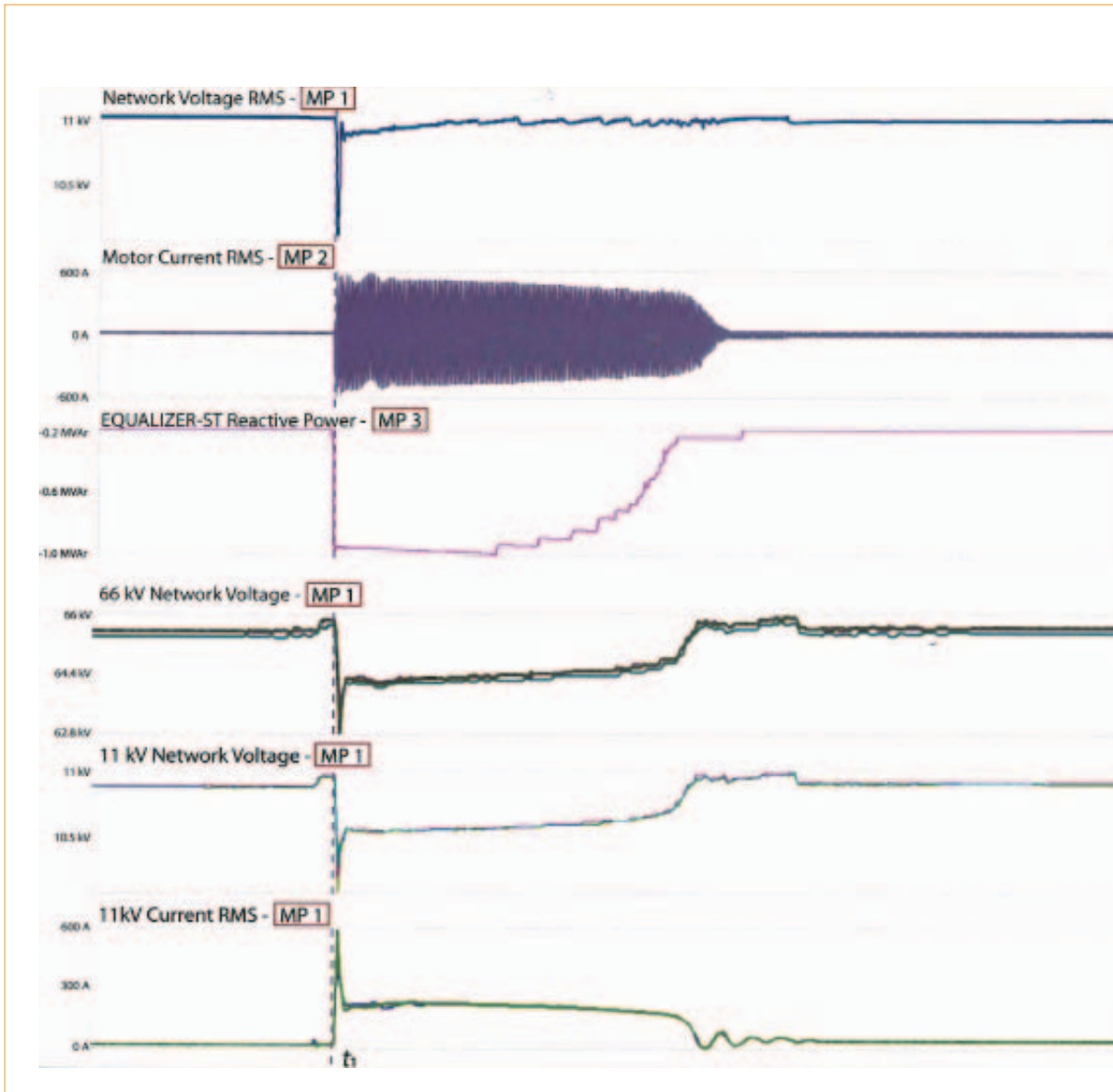

Actual Electrical Diagram – 11 kV & Network

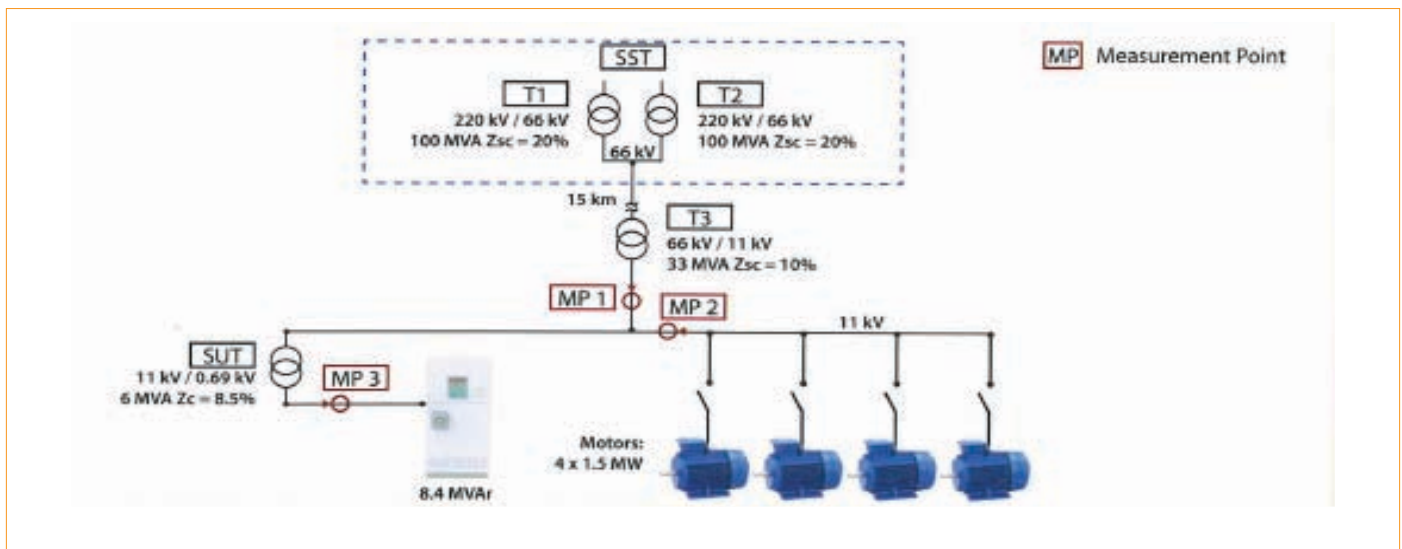

BlackBox G4500

The 3 Phases Portable PQA

The BlackBox portable series power quality analyzer takes power quality monitoring to a whole new level by using the revolutionary PQZIP patent algorithm. The unique algorithm enables you to measure, store & analyze (continuously) waveform signals regardless their size.



With the G4500 each event, no matter its size, is recorded

When it comes to power, you don't want to leave it to the unexpected. In our field, we are looking for solutions allowing us to better measure, store and analyze power quality. We want to make sure that all the information gathered is accurate, in high resolution and without the need of configuring an event.



The Issue:

Event or Incidence?

While an event is configured by the user based on statistics and knowledge, an incident is a real occurrence. Take for instance a production line failure.

The correlation between an event and an incidence depends on the level of statistics and knowledge held by the user. Indeed, to avoid recurring incidences, the user needs to analyze them. If the event is not well configured, the incidence will not be interpreted correctly or will be missed. In another case, too many events may be randomly recorded which may result in over storage of useless information in the memory's device.



The Solution:

Elspec's PQZIP's unique Patent

With Elspec's PQZIP, You Will Get the Unique Advantage of :
Continuous Waveform Recordings

PQSCADA Sapphire

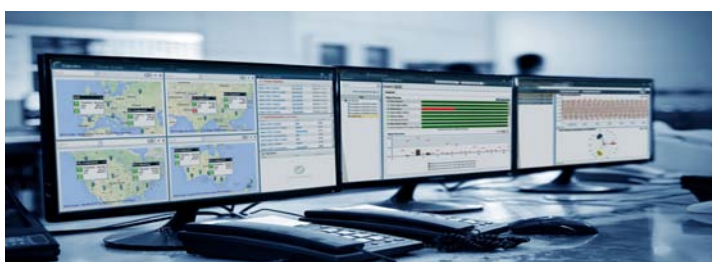

PQSCADA Sapphire allows all Fault Recorders, Power Quality Analyzers, Revenue Meters and all other IED to be analyzed in one system. Learn more about PQSCADA Sapphire on page 37

Get Much More than a Box!



I/O

The I/O Ports of the portable BLACKBOX extend the monitoring capabilities of the device by using additional digital & relay ports.

Web Interface

No need for software! Connect directly to any PC and get real time measurements and results. A user friendly and easy way to get precise information and data.

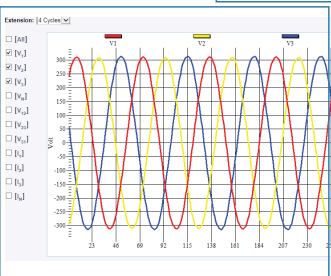

Battery

Battery life of up to 2 hours allowing continuous measurement and recording.

Clamps

Elspec's unique calibration procedure calculates both the clamp and device inaccuracy, allowing to eliminate clamps uncertainty, and to yield superior power measurement accuracy.

VDC/IDC

The G4500 offers VDC/IDC input

Wi-Fi

No need for cables. Easy to use everywhere.

Plug-and-Play

The Portable BLACKBOX is equipped with a plug-and-play probe interface allowing automatic detection of probes and clamps during setup.

Voltage inputs

The BlackBox is equipped with 4 AC and 2 DC voltage channels to measure any available power configuration.

Current Inputs

The BLACKBOX is equipped with 4 AC current channels in order to measure a 3-phase + Neutral and an additional 1 AC/DC channel for earth/DC signal.

USB

For cellular communication.

Harmonics Recording

The BLACKBOX is equipped with two FFT engines for harmonics analysis:

- Cycle by Cycle: performs FFT at 1 cycle resolution for extended bandwidth. This engine provides 512 harmonic component at 50/60Hz resolution.
- 10/12 Cycles: performs FFT at 10/12 cycles resolution for an extended resolution and a sub-grouping calculation. This engine provides the amplitude and angle of 512 harmonic components at a 5Hz resolution.

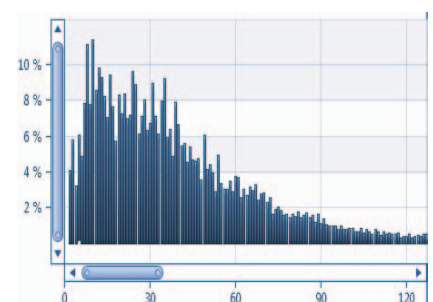

Optional Accessories

DC Current Clamp

Ordering Information (Part Number)	SOA-0270-1400
Current Measurement	1,500A DC / 1,000A AC
Output Signal	1m V/A, 10m V/A
Operating Temperature	- 20°C to + 60°C
Cable Length	1.4m



1 - 6A Mini Clamp

Ordering Information (Part Number)	SOA-0010-0500
Measurement Range	Up to 6A AC (1A Nominal) Up to 60A AC (10A Nominal) *
Output Signal	100m V/A
Operating Temperature	- 20°C to + 60°C
Cable Length	1.2m



100A Mini Clamp

Ordering Information (Part Number)	SOA-0180-5000
Measurement Range	Up to 100APK AC
"Hole" Dimensions	10mm Max
Operating Temperature	- 20°C to + 60°C
Cable Length	1.2m



Custom Clamp 3-Flexible Current Probes

Ordering Information (Part Number)	SOA-3003-0270
Current Range	30A/300A/3000A AC RMS
Operating Temperature	- 20°C to + 65°C
Probe Cable Length	610mm (24")
Probe Cable Diameter	194mm (7.5")



3000A /300A Flexible Current Clamps

	3000A	300A
Ordering Information (Part Number)	SOA-9045-3001	SOA-9045-3000
Current Range	90A - 4,200A	9A - 1,050A
Operating Temperature	- 20°C to + 60°C	- 20°C to + 60°C
Cable Length	2m	2m
Loop Diameter	80cm	45cm



GPS (Global Positioning System)

The GPS provides an optimal mobile time synchronization solution for accurate time data via satellite signal. In the absence of many other technologies, it enables time synchronization at any remote site location.

Multi Frequency Modem

USB modem with a SIM card can be connected to USB port to allow cellular communication. The wireless GPRS modem provides fast mobile communication access and offers the perfect solution in industrial data communication. It is fitted with a SIM card drawer structure, and it may be connected with any standard RS-422 interface. Data is transmitted at 3.5G. The modem is fully compatible with GSM/GPRS/EDGE.

Class A Test Reports

Elspec can provide upon request, a comprehensive functionality and calibration test report for each analyzer. Fully automated calibration software is also available for customer's in-house use.

Full Compliance with Class A

The BLACKBOX portable series complies fully with IEC 61000-4-30 most updated edition Class A standard. Other parameters, not included in the standard (i.e. current and power), are calculated with comparable methods required by the standard.



Specifications

Waveform Sampling			
Voltage Sampling Rate		1024 Samples/Cycle	
Current Sampling Rate		256 Samples/Cycle	
Voltage Harmonics (Individual, Even, Odd, Total) Up to -		511 th	
Current Harmonics (Individual, Even, Odd, Total) Up to -		127 th	
Type of Analog to Digital Converter		16/20 ¹ bit	
Storage Capacity			
Internal Memory		32 GB/32TB ²	
Power Quality Analysis			
Transient Detection, Microseconds (50Hz/60Hz)		19.5/16.3μs	
Communication Ports			
Ethernet Ports		3	
Wi-Fi Communications (802.11g)		1	
Power Over Ethernet (PoE- Out)		1	
Digital Input		4	
RS-232		1	
RS-485		1	
Physical			
Dimensions mm		314 X 84 X 271	
Weight		3.7kg	
Control			
Comprehensive web server for local and remote real-time monitoring and control			
Applicable Standards			
Measurement Standards		EN50160, IEEE1159, IEEE519, IEC61000-4-15, IEC61000-4-7, IEC61000-4-30 Class A	
EMC Standards		EN61326, CFR47FCC, CISPR11 Group 1, FCC PART 15 Subpart B, EN61010-2, IEC61000-3-3, IEC61000-4-2, IEC61000-4-3, IEC61000-4-4, IEC61000-4-5, IEC61000-4-6, IEC61000-4-11	
Environmental Standards		IEC60068-2-1, 2, 6, 27, 30, 75	
Safety Standards		EN61010-1:2001 2nd Edition	
Power Supply		Voltage	
Operating Range	100-260 VAC: 50/60 Hz 100-300 VDC	Voltage Channels	4 (3 Phases + Neut.)+ 1 DC
		Nominal Full Scale	1000V
Auxiliary DC Supply	48 Vdc	Maximum Peak Measurement	4000V
Auxiliary Supply	PoE In According to 802.3af	Input Impedance	3MΩ
Battery Backup	2 Hours	Uncertainty	0.1% of Nominal
Time		Current	
Real Time Clock	±1 Second per 24 Hours	Current Channels	4 (3 Phases + Neut.)+ 1 Grn/DC
GPS	100-200μs	Current Channels Receive From Clamp	I1-I4: 0-10 VPK I5: 0-3 VPK
IRIG B	100-200μs	Uncertainty	0.1% ±0.1 mV
SNTP Server	50-100μs	Frequency	
DCF-77	±15ms	Fundamental Frequency	42.5 Hz to 69 Hz
Environmental Conditions		Frequency Resolution	10 mHz
Operation Temperature	0°C – 50°C (32°F – 122 °F)	Frequency Accuracy	±10 mHz
Storage Temperature	-20°C – 60°C (-4°F – 140 °F)	Disclaimer: Specifications subject to changes without prior notice	

A comprehensive energy management and power monitoring program is the key to success for any energy provider/consumer, regardless their size. The BlackBox G4400 series, the most advanced power meter in the market today, is equipped with the revolutionary PQZIP patent algorithm for continuous waveform recording. It enables you to predict, prevent and troubleshoot an incidence easily, without the need to set any triggers or thresholds in order to capture a specific event or events.



Utilities

(Transmission, distribution, generation)

- Optimizes protective equipment configuration and substation automation solutions
- Ensures a reliable & consistent supply of energy
- Evaluates the performance of breakers and relays
- Identifies and manage peak demand
- Real time power quality monitoring to meet any international standard
- Produces detailed & comprehensive statistical records

Energy Consumer

(Critical power, industrial, commercial, government etc.)

- Measures & analyzes system efficiency, provides solutions and increases profits
- Negotiating capabilities with power providers
- Detect electric bill inconsistencies
- Avoid PQ compliance issues
- Real time PQ monitoring and analysis

Elspec's Unique Technology

PQZIP Compression Technology

The PQZIP Patent compression algorithm enables the meter to continuously store waveform signals over a long period of time, whether an event of interest was identified. This technology is unique to Elspec and ensures precise and accurate characterization of electrical system dynamics.

PQZIP Compression features:

- ✓ Continuous waveform recording
- ✓ Supreme Trend Resolution
- ✓ Extended Harmonic Recording
- ✓ Threshold free setup
- ✓ Easy deployment

Parameter	Resolution
Waveform	20μsec
RMS	½ Cycle
THD	½ Cycle
TDD	½ Cycle
Unbalance	½ Cycle
K Factor	½ Cycle
Crest Factor	½ Cycle
Powers	1 Cycle
Harmonics	1 Cycle
Frequency	1 Cycle

Discover Outstanding Features

Dual Range Gain

Elspec's pioneering measurement method uses a dual-range gain of 2 X 16 bit ADC yield, a superior accuracy and resolution. Therefore, the use of a 16 simultaneous ADC (each one with 1,024 sample/sec), provides incomparable accuracy with no cross-channel lags or interconnections.

Accuracy standards

The G4k superior accuracy surpasses by far, the highest standards set by the industry. The BLACKBOX device series compiles with standard for:

Power Quality

- ✓ IEC 61000-4-30 Class A
- ✓ IEC 61000-4-15 Flicker meter
- ✓ IEC 61000-4-7 Harmonics and inter-harmonics

Energy

- ✓ ANSI C12.20 0.2%
- ✓ IEC 62053-22/23 class 0.2

Temperature Adjustment

The G4k adjusts automatically its calibration parameters based on real time temperature reading.

SCADA Compatible

The G4400 series is equipped with standard industrial protocol for seamless integration into any existing SCADA system:

- ✓ Modbus TCP/IP and RTU
- ✓ DNP 3
- ✓ OPC

High End Power Quality and billing measurement

Thousands of power quality and energy usage parameters are available in real time in the G4400 series. The G4400 series provides advanced power disturbance recordings meeting the highest standards on the market. The meter is designed with the most accurate level in order to be used as a primary meter, a sub-meter, as a detector of inconsistencies in electricity bills.

Time Synchronization

The G4400 series uses a special continuous synchronization algorithm to ensure accurate time stamping of up to 1µsec using SNTP, GPS, IRIG-B and DCF-77.

Each G4400 meter acts as a SNTP server therefore each meter on the network is synchronized to each other over LAN. This allows accurate time stamping, without the need of a GPS.

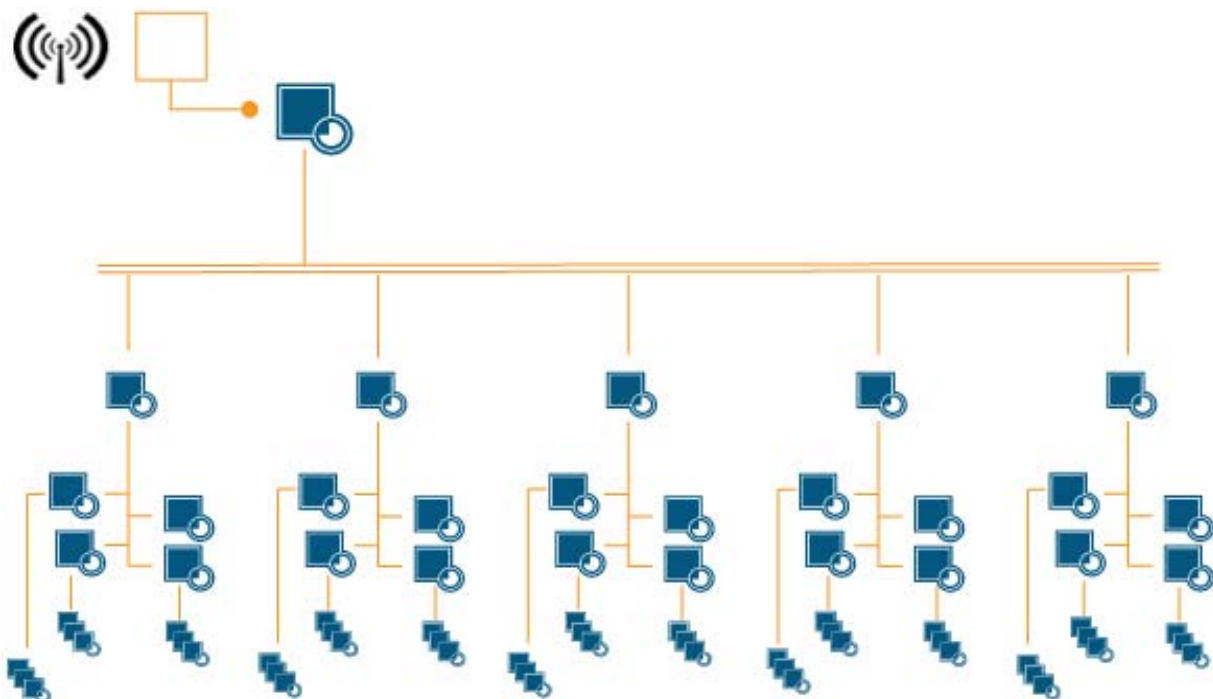

Optional Accessories

Multi I/O extension to comply with every application

The G4400 series offers the option to extend the meter capability by adding the multi I/O module in conjunction with all metering functionalities. The I/O module includes analog and digital I/O as well as a relay output to specifically work with your application. The multi I/O module extends the meter capability in order to replace RTUs and PLCs for energy management and substation automation. With the G4400 series you can monitor the reliability of system apparatus such as transformers, circuit breakers and other critical equipment. The G4400 series supports up to 2 I/O modules using internal power along with:

- ✓ 8 fast digital input at 16 sample/sec
- ✓ 4 fast digital output at 16 sample/sec
- ✓ 4 analog 4-20mA input sampled at 1Hz with programmable scaling
- ✓ 4 analog 4-20mA output
- ✓ 3 Relays



Real Time Local & Remote Monitoring

The G4400 series is accessible locally or remotely, using either an integral web server interface or the Elspec G4100 remote display. The Elspec G4100 represents the next generation in power network information exchange. By using IP based communication, various unprecedented setup configurations are enabled over a great distance. Using Ethernet infrastructure, the G4100 can monitor multiple G4400 meters connected to the network remotely or connected to each analyzer directly. The G4100's display provides full control over all meters allowing technicians and field operators to fully configure and operate each single meter in the network. The G4100 can be powered by external power supply or through the G4400 embedded PoE port.



GPS

The GPS provides an optimal mobile time synchronization solution for accurate time data via satellite signal. In absence of many other technologies, it synchronizes the time at any remote location.



PQSCADA Sapphire

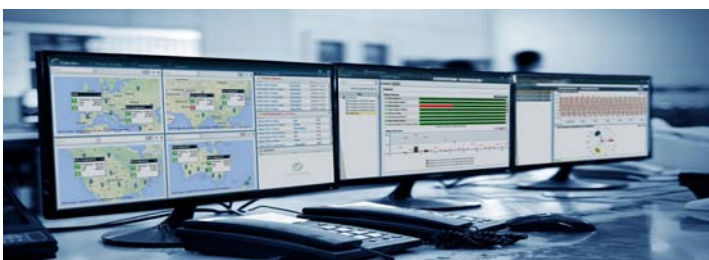

PQSCADA Sapphire allows all Fault Recorders, Power Quality Analyzers, Revenue Meters and all other IED to be analyzed in one system. Learn more about PQSCADA Sapphire on page 37

Specifications

Product Series	G4410	G4420	G4430
Voltage Sampling Rate, Maximum Samples/Cycle	256	512	1024
Voltage Harmonics (Individual, Even, Odd, Total) Up to -	127 TH	255 TH	511 TH
Type of Analog to Digital Converter	16/20 ¹ bit	16/20 ¹ bit	16/20 ¹ bit
Storage Capacity w			
Internal Memory	128 MB	4 GB	16 GB
Power Quality Analysis			
Transient Detection, Microseconds (50Hz/60Hz)	78.1/65.1µs	39/32.5µs	19.5/16.3µs
Communication Ports			
Ethernet Ports	1	2	2
Power Over Ethernet (PoE- Out)	-	1	1
Voltage Ride Through on Power Loss (up to)	10 sec.	25 sec.	25 sec.
Specifications			
Applicable Measurement Standards		Control	
EN50160, IEEE1159, IEEE519, IEC61000-4-15, IEC61000-4-7, IEC61000-4-30 Class A, IEC62053-22/23 Class 0.2		Comprehensive web server for local and remote real-time monitoring and control	
Applicable EMC Standards		Applicable Environmental Standards	
EN55011 Group 1 Class A, EN60439-1 (clauses 7.9.1, 7.9.3, 7.9.4, 7.10.3, 7.10.4), FCC Part 15 Subpart B Class A, IEC61000-3-3, EN61000-6-2, IEC60255		IEC60068-2-1, 2, 6, 11, 27, 30, 75	
Voltage		Applicable Safety Standards	
Channels	3 Phase + Neutral	EN61010-1:2001 2 nd Edition	
Nominal Full Scale	1000V	Power Supply	
Maximum Peak Measurement	8kV	Auxiliary Supply – PoE In	According to 802.3af
Input Impedance	3MΩ	Auxiliary DC Supply	48 Vdc
Uncertainty	0.1% of Nominal	Operating Range	100-260 VAC: 50/60 Hz 100-300 VDC
Current		Time	
Channels	3 Phase + Neutral	Real Time Clock	20ppm
Nominal Full Scale	5A	Synchronization Device	Accuracy
Maximum Peak Measurement	50A	GPS	100-200µs
Burden	0.0001VA@5A	IRIG B	100-200µs
Phase	±0.42°@3A ±0.17°@5A	SNTP Server	50-100µs
Uncertainty	0.1% of Nominal	DCF-77	±15ms
Frequency		Communication Protocols	
Fundamental Frequency	42.5 Hz to 69 Hz	Modbus TCP, Modbus RTU, OPC, DNP3 SMTP Client	
Frequency Resolution	10 mHz	RS-485/422	
Frequency Accuracy	±10 mHz		
Physical		Environmental Conditions	
Dimensions	175mm x 232mm x138mm	Operation Temperature	-20°C to 70°C(-4°F to 158°F)
Weight	1.7Kg	Storage Temperature	-40°C to 85°C(-40°F to 185°F)

¹ Effective bits

Disclaimer: Specifications subject to changes without prior notice

BlackBox Pure

3/1 Phase Power Quality Analyzer

The Pure BlackBox, an advanced Class A power quality analyzer embedded with PQZIP Technology, is an easy to use plug and play device that continuously records all power quality parameters without thresholds setting or recording configuration.

The device is available in 2 versions:
Single Phase, 3-Phase



Handy and Ready

When using the Pure BlackBox, any installation errors such as a wrong phase order can be fixed during post-processing. The Pure BlackBox includes a ride through super capacitors technology to enable continuous recording during short supply interruptions.

Power quality post recording processing and analysis are available using the free SCADA Sapphire Express Edition software. Use it via drag and drop of recorded data for immediate analysis, PQ trending, events and reports.

Recorded information are saved in a non-volatile memory SD card which can be accessed as a standard external memory either via the device USB slot connected to a PC, or by inserting the SD card in a reader connected to a PC.

Features

- ▶ Continuous Waveform recording at 256 Sample/Cycle
- ▶ Class A devices IEC30-4-61000
- ▶ Configuration FREE Device
- ▶ Fast USB connectivity to PC
- ▶ SD card slot hot swap
- ▶ Optional battery bank and communication extension for remote data collection over LAN network, wireless Wi-Fi or cellular communication
- ▶ IP40 for rugged environments
- ▶ Lightweight, hand-held portable PQ recorder
- ▶ Easy to use
- ▶ Two-sided mounting clip for convenient installation of a din rail, magnet or nail mounting.

PQSCADA Sapphire

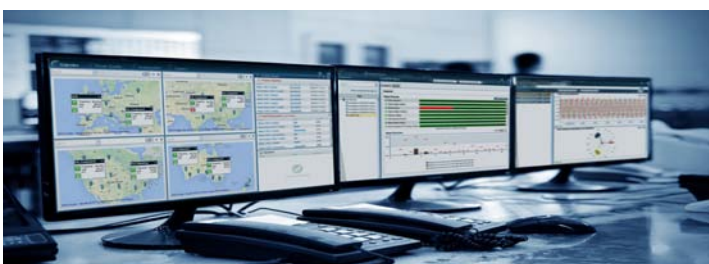

PQSCADA Sapphire allows all Fault Recorders, Power Quality Analyzers, Revenue Meters and all other IED to be analyzed in one system. Learn more about PQSCADA Sapphire on page 37

Get Much More than a Box!

Plug & Play Power Quality Analyzer

The BlackBox Pure is a plug and play analyzer. Upon connection, the Pure begins recording voltage and current waveforms then stores them in a proprietary PQZ format. No pre-configuration or thresholds are required.

Rugged & Compact

The Pure BlackBox is designed for an easy and safety installation. It is equipped with dedicated mounting clip-on to facilitate convenient installation to Din Rail, magnet or nail mounting.

Power Output

The 3-phase Pure BlackBox includes DC power output port with selectable voltage level to energized external accessories such as clamps.

Voltage Inputs

- 3 Phase: The 3 Phase Pure BlackBox equipped with 4 AC voltage channels (3 Phases + Neutral) to measure any available power configuration.
- 1 Phase: the Single Phase Pure BlackBox equipped with 2 AC voltage channels (1 phase + neutral)

Current Inputs

- 3 Phase: The 3 Phase Pure BlackBox equipped with 4 AC current channels to measure 3 phase + neutral
- Single Phase: the Single Phase Pure BlackBox equipped with 1 AC current channel to measure single phase load power and energy consumption.

3 Phases

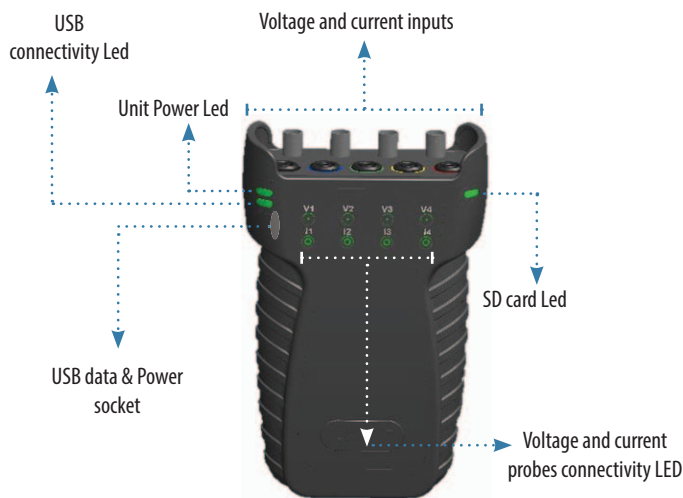

Single Phase



Extension Module

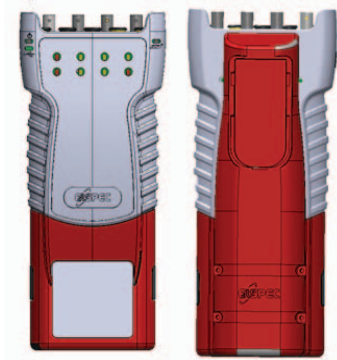

AC power supply
 LAN port (RJ45)
 USB - data & DC power supply or wireless communication WiFi/ 3G dongle
 Battery power/backup source of up to 4 hours

Protective Case



Protects the device from scratches and shocks.
 Available for both models.

DC Current Clamp

Ordering Information (Part Number)	SOA-0270-1400
Current Measurement	1,500A DC / 1,000A AC
Output Signal	1m V/A, 10m V/A
Operating Temperature	- 20°C to + 60°C
Cable Length	1.4m



1 - 6A Mini Clamp

Ordering Information (Part Number)	SOA-0010-0500
Measurement Range	Up to 6A AC (1A Nominal) Up to 60A AC (10A Nominal)*
Output Signal	100m V/A
Operating Temperature	- 20°C to + 60°C
Cable Length	1.2m



100A Mini Clamp

Ordering Information (Part Number)	SOA-0180-5000
Measurement Range	Up to 100APK AC
"Hole" Dimensions	10mm Max
Operating Temperature	- 20°C to + 60°C
Cable Length	1.2m



Custom Clamp 3-Flexible Current Probes

Ordering Information (Part Number)	SOA-3003-0270
Current Range	30A/300A/3000A AC RMS
Operating Temperature	- 20°C to + 65°C
Probe Cable Length	610mm (24")
Probe Cable Diameter	194mm (7.5")



*Selectable software range

Specifications

Product Seiries	3 Phase	Single Phase
General		
Voltage input	4 channels, 110-690VAC Nominal Measuring up to 1.5kV RMS	2 channels, phase and neutral through power socket 110/240VAC Nominal Measuring up to 0.5kV RMS
Current Channels	4 channels Voltage output CTs (0-10V peak)	1 channel, between source and load up to 10A Peak
Line Frequency	40-70Hz	40-70Hz
Sampling Rate	256 Samples/Cycle @ 50/60Hz	256 Samples/Cycle @ 50/60Hz
LED Indicators	11 Bi-color LED: Voltage clips status - 4 Current clamps status - 4 SD card status - 1 PQZ Recording status - 1 General status - 1	3 Bi-colors LED SD card status - 1 PQZ Recording status - 1 General status - 1
Accuracy	IEC 61000-4-30 Class A	IEC 61000-4-30 Class A
Communication		
LAN	Available in extension module	N/A
USB	PQZ file download, FW upgrade & clock setting	PQZ file download, FW upgrade & clock setting
Power		
Power Supply	100-240VAC 50/60Hz 10W 140-300VDC 5VDC over USB	100-240VAC 50/60Hz 10W 5VDC over USB
Ride Through	30sec	15sec
Battery	5h with extension module	N/A
Mechanical		
Weight	0.4kg	0.25kg
Dimensions	180 x 115 x 60	146 x 82 x 48
Synchronization		
External synchronization	NTP available in extension module	N/A
Internal Synchronization	10ppm	10ppm
Environmental		
Operating Temperture	-20 to +70°C*	-20 to +70°C*
Humidity	5% to 95% non-condensing	5% to 95% non-condensing
IP Protection	IP 40	IP 40
Storage		
Nonvolatile Memory	SD card supporting hot swap*	

(*) T>60°C requires an external power supply

(**) see SD card specifications in user manual

Disclaimer: Specifications subject to changes without prior notice

The BlackBox DFR, a fully featured digital fault recorder embedded with PQZIP technology, is a distributed multi-functional data acquisition device that continuously records all waveform signals at sampling rate of 1,024 Sample/Cycle. The continuous waveform recording makes the BlackBox DFR ideal for monitoring, protecting operating, power quality, synchro phasors and load profiles. The BlackBox DFR modular design allows to expand the system to almost any application in order to offer a cost effective performance. When coupled with Elspec PQSCADA Sapphire - a multi-vendors support power management software- the BlackBox DFR provides a powerful platform for acquisition, analysis and report of data from power system substations.



Multi-Functional

- Digital Fault Recorder (DFR)
- Phasor Measurement Unit (PMU)
- Power Quality Monitoring (PQM)
- Sequence of Event Recording (SER)
- Dynamic System Monitoring (DSM)
- Impedance based Fault Location (IbFL)
- Energy Billing Measurement (EBM)

Features

- 24-Bit Continuous acquisition at 1,024 sample per cycle[50/60Hz]
- Modular Design
- Centralized and decentralized architecture
- Supreme synchronization <0.1 μsec on any channel
- 7" touch LCD
- Comprehensive web interface
- Scalable architecture
- Complies with IEC 61850 MMS, GOOSE messaging and sample value

PQSCADA Sapphire

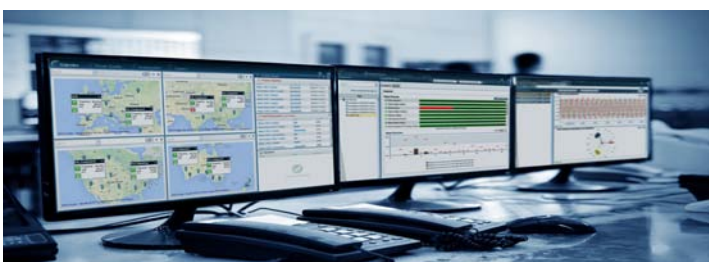

PQSCADA Sapphire allows all Fault Recorders, Power Quality Analyzers, Revenue Meters and all other IED to be analyzed in one system. Learn more about PQSCADA Sapphire on page 37

Discover Outstanding Features

Web Interface

The BlackBox G5DFR is equipped with a fully web server using HTML5 web technology. It allows interfacing with any web-enabled device using most web browsers. Access to the web interface is secured with a user name and password. The web interface is used for the configuration and monitoring. The BlackBox G5DFR web interface includes 2 main modules:

- Overview: Shows at a glance a full status of measurements and system statuses
- Investigation: The Investigation module shows graphs of trends, histograms, events lists, summary tables, and statistical summaries of all stored parameters. It allows the user to analyze voltage sags/dips, swells, interruptions, and any other incident. Each investigation includes multiple charts.



LCD

The BlackBox G5DFR is equipped with a 7" touch screen display in high resolution along with led backlight and 1.100 000 colors.

Communication

The BlackBox G5DFR rear panel is equipped with

- 2 SFP Ethernet ports for communication to either two separate networks or for redundant communications. The SFP is a hot-swappable input/output device allowing multiple options of connectivity.
- 2 USB ports extend the DFR wireless communication capabilities by connecting standard USB communication sticks.
- 1 serial RS232 port

Additional Ethernet, serial and USB ports can be added to the front panel for use by field technicians.

4x
USB

2x
SFP

2x
Serial

Power Quality

The BlackBox G5DFR provides a comprehensive power quality module; that fully complies with IEC 61000-4-30 class A, for analysis and presentation. Power quality measurements available include:

- Harmonics recording: Compliant to IEC 61000-4-7, the harmonic recording is available for all 32 virtual channels. 100 harmonics and 100 inter-harmonics subgroup quantities per channels can be recorded at a resolution of 10/12 cycles, 150/180 cycles, 1min and 10min continuously.
- PQ Events: Compliant with IEC 61000-4-30 Class A, the power quality module can detect voltage sags (dips), swells, interruptions, and rapid voltage changes for all 32 virtual channels. The PQ module includes event aggregation for poly-phase system support.
- Flicker recording: Compliant with IEC 61000-4-15.

All power quality parameters are continuously logged-in at ½ cycles 150/180 cycles, 10min and 2 hours resolution for up-to 1 year.

10k
parameters

1k
samples

512
harmonics

Energy Meter

The BlackBox G5DFR is equipped with a high precision 4 quadrat energy meter with 0.1% accuracy in power & energy.

Fault Location

The BlackBox G5DFR is equipped with a one and two-terminal impedance-based distance to fault calculation algorithm.

The accurate results increase the network reliability and availability by:

- Reduce aerial patrol costs
- Prevent re-occurring faults
- Reduce power quality impact of 'preventable faults'
- Reduce cost of regulatory fines due to power outage

Detected faults:

- Three-phase short circuit
- Two-phase short circuit
- Two-phase short circuit to ground
- Single-phase short circuit to ground
- Single-phase open wire

PMU

- Complies with the most updated standard for synchro-phasor measurements of power systems IEEE C37.118-2011, including the amendment IEEE C37.118.1a-2014
- Two independent synchrophasor data streams enabling to report a synchrophasor data with two different report-rates and/or different performance classes (P/M) and/or data type simultaneously.
- Ultra-fast report rate for both P & M classes.

Performance Class	Max report rate for 50Hz	Max report rate for 60Hz
P	200/sec	240/sec
M	100/sec	120/sec

- Phasor measurement reporting function for up to 32 phasors on each data stream.
- Streaming of any of the 10,000 calculated analog data parameters is available via the PMU protocol, eliminating the need to calculate power parameter in the PDC or anywhere else.
- Analog data streaming also include streaming of mili-Amp input signals for control purposes. There is no need to use any other means to transfer transducer's signals
- Support for simultaneous synchrophasor data stream over TCP/IP and UDP/IP. It can be configured for unicast or multicast, enabling a better design of WAMS communication and suitable for WAMS with several utilities or applications involved.

Time Synchronization

The BLACKBoxDFR's synchronization algorithm is based on several sources with an automatic hierarchy for the preferred source availability (accuracy based hierarchy). The main time source serves as the primary/external time synchronization source while the alternative time sources are used as the secondary time source in case the primary source fails. The Table below outlines the accuracy of the BLACKBOX G5DFR's individual time sources.

Time Source	Accuracy
Internal Clock	±10ppm
NTP	100µsec
GPS/IRIG B	0.5µsec
DSP Sync	0.1µsec

Standard synchronization methods such as GPS, IRIG-B, NTP, etc., synchronize the time stamp of the signal. However in a power quality application in general, and especially in continuous waveform recordings, the sampling frequency between devices must be synchronized as well. Elspec's propriety time synchronization algorithm is a cost effective, high performing technology, able to achieve a simultaneous synchronized sampling from hundreds of channels in a decentralized redundant architecture. Each individual BLACKBOX G5DFR acts as a Sync Master, and therefore can be used as a time reference to other units at a time accuracy of 50-100nsec.

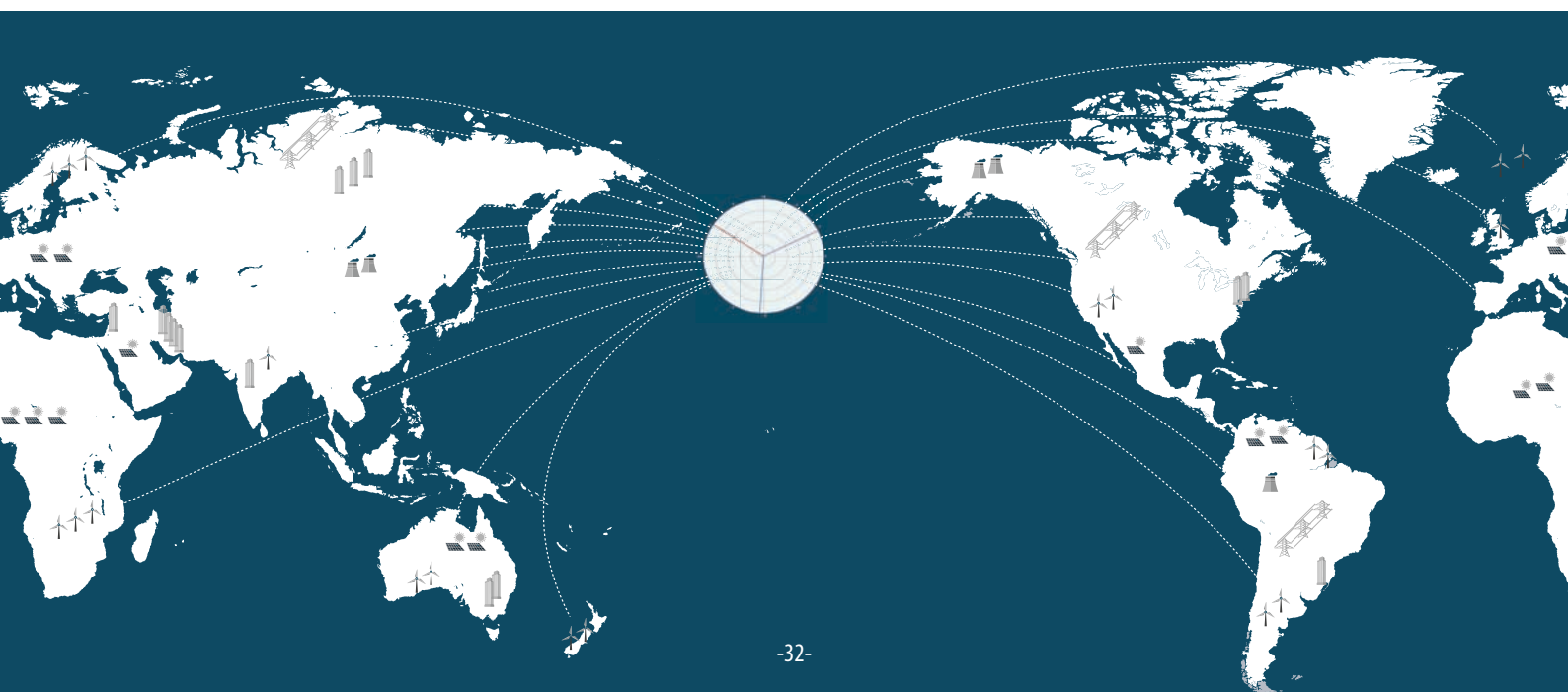

Flexible Architecture

The system architecture of the BlackBox G5DFR enables the concentration and the monitoring of a large array of analog and binary channels as well as controlled and processed signals. The G5 DFR is a ½ 19" rack mount device that include 1 CPU module, 1 PSU module and 1 data acquisition unit. The data acquisition unit is assembled out of 5 data acquisition cards performing the following functions:

- Connection to the input/output signals
- Filtering and isolation
- Analog/digital conversion
- Synchronized sampling for all channels

The Data acquisition cards are divided into two main groups:

- Analog cards – each device can be mounted with up to 2 analog cards. The analog card measures fast analog channels (voltage and currents) at various ranges and sampling rate. Based on the waveform raw data capture by those cards, the CPU calculates displays and stores 10,000 different power parameters. Each analog card can hold up to 8 analog channels
- Auxiliary cards – the auxiliary cards extend the G5DFR capabilities by adding various I/O signals such as digital I/O, process signals I/O 4-20mA and relays output. The auxiliary cards are continuously sampled and stored at 128 samples/cycle.

DFR at a Glance

General View with Connectors



Back View

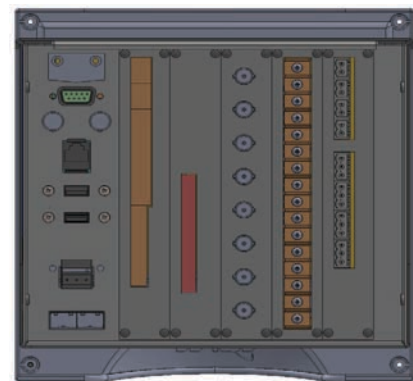

Side View with Measurements

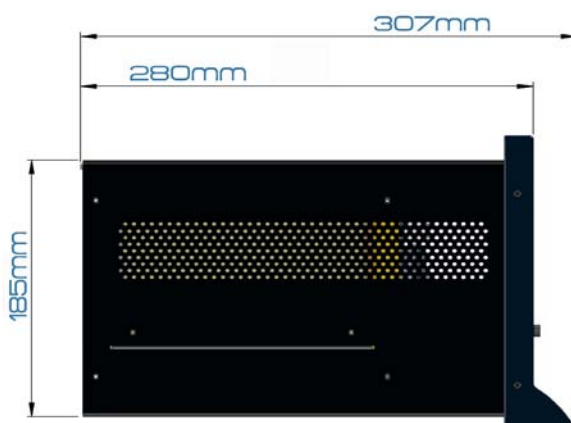

Front View with Measurements

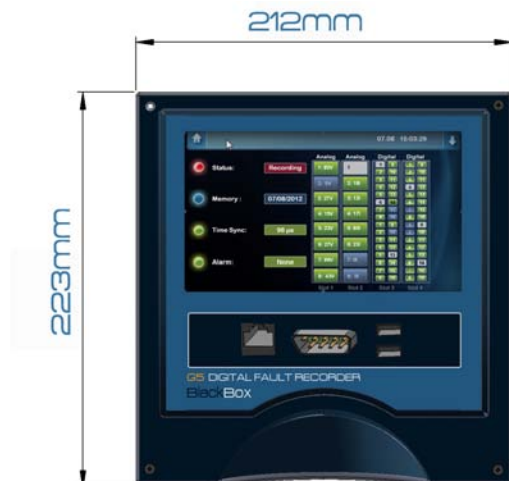

Specifications

Basic Unit

Data Acquisition		
Recording period	1 Week	
	1 month	
	1 year	
Analog Channels Sampling Rate	256 Sample/Cycle	
	512 Sample/Cycle	
	1,024 Sample/Cycle	
Digital & Aux Channels Sampling Rate	128 Sample/Cycle	
Mechanical		
Dimensions [W X H X D]	21.5 x 22.1 x 29.1 cm (8.48" x 8.7" x 11.45")	
Frequency		
Fundamental Frequency	37 – 70Hz	
Frequency Resolution	1mHz	
Frequency accuracy	±1mHz	
Type of Analog to Digital Converter	24 Bit	
PMU*		
Applicable Standard	IEEE C37.118 – 2011	
M Class transmission Max rate	100/sec for 50Hz, 120/sec for 60Hz	
P Class Transmission rate	200/sec for 50Hz, 240/sec for 60Hz	
Communication		
Rear Panel	SFP Ports (100/1,000MB/s)	2
	Serial Ports	1
	USB PORTS	2
	PPS	1
Front Panel*	USB PORTS	2
	Ethernet Port (10/100MB/s)	1
	USB Port	2
	Serial	1
Communication Protocols		
IEC 61850	MMS, GOOSE, Sample Value*	
MODBUS	TCP/IP, RTU**	
Power Supply		
Main	100-260 VAC @50/60 Hz or 100-300 VDC	
Aux	24VDC	
Time		
Internal Real Time Clock	20 _{PPM}	
GPS	0.5µsec	
IRIG B	0.5 µsec	
NTP	100 µsec	
Environmental Conditions		
Operation Temperature	-20°C to 70°C (-4°F to 158°F)	
Storage Temperature	-40°C to 85°C (-40°F to 185°F)	
Human Machine Interface		
Built in 7" 1MP LCD. Additional comprehensive web server for local and remote real-time monitoring, historical data analysis and control.		

Ordering Options

1. Software Features

- Modbus interface
- IEC 61850 – MMS, GOOSE, Sample Values
- Phasor Measurement Unit (PMU)

2. Front Panel communication ports:

- 2xUSB
- 1xSerial
- 1xLAN

3. Analog Cards: up to 2 cards per unit

3.1. Analog Cards: 4V/4I (50A)

Voltage full range scale	500V/1,500V/4000V
Voltage accuracy	0.1% from Nominal
Current sensor type	CT/ Hall Effect
Capacity	50A (for 5sec)
Thermal withstand	10A continuous
Current accuracy	0.1% from Nominal
Current full scale	5A

3.2. Analog Cards: 4V/4I (100A)

Voltage full range scale	500V/1,500V/4000V
Voltage accuracy	0.1% from Nominal
Current sensor type	CT/ Hall Effect/Shunt
Capacity	100A (for 5sec)
Thermal withstand	10A continuous
Current accuracy	0.1% from Nominal
Current full scale	5A

3.3. Analog Cards: 8I (50A)

Current sensor type	CT/Hall Effect
Capacity (for 5sec)	50A
Thermal withstand	10A continuous
Current accuracy	0.1% from Nominal
Current full scale	5A

3.4. Analog Cards: 8I (100A)

Current sensor type	Hall Effect
Capacity (for 5sec)	100A
Thermal withstand	10A continuous
Current accuracy	0.1% from Nominal
Current full scale	5A

3.5. Analog Cards: 8V

Voltage full range scale	500V/1,500V/4000V
Current accuracy	0.1% from Nominal

3.6. Analog Cards: 4LV 4V

Number of high voltage channels	4
Voltage range full scale	500V/1,500V/4000V
Current accuracy	0.1% from Nominal
Number of low voltage channels	4
Voltage range full scale	+/- 10V
Accuracy	0.1% from Nominal

4. Auxiliary Cards: Up to 5 cards per unit

4.1. Digital Input

Number of channels	32		
Range	48 VDC ($\pm 20\%$)	115 VDC ($\pm 20\%$)	230 VDC ($\pm 20\%$)
Activation threshold	24 VDC	92 VDC	176 VDC
Undefined range	5-24 VDC	5-92 VDC	5-176 VDC

4.2 Digital Output

Number of channels	16
Range	115 VDC ($\pm 20\%$)
Activation threshold	92 VDC
Undefined range	5-92 VDC

4.3 Relay Output

Number of contacts	8
Contact arrangement	1 form C (CO)
Rated voltage	250VAC
Max. switching voltage	400VAC
Rated current	16A
Limiting continuous current	16A
Max. 4sec, duty factor 10%	30A
Breaking capacity max	4,000VA
Operate/release time max., DC coil	8/6ms

System Overview

Elspec PQSCADA Sapphire allows all Fault Recorders, Power Quality Analyzers, Revenue Meters and all other IED to be analyzed in one system



Alarm & Control



Real Time Overview



Advanced PQ Analysis



Report Customization



Historical Data Investigation



Fault Location

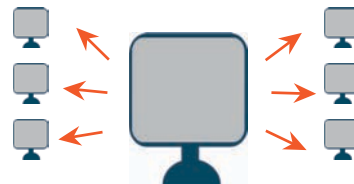

Local & Remote Work Stations

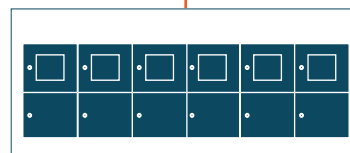
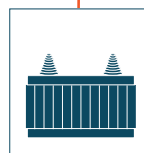
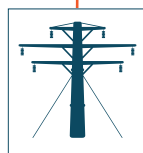
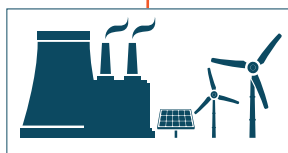

Introduction

In today's world, power distribution networks deploy an array of protection equipment, power quality analyzers, revenue meters and other monitoring equipment to ensure high quality and reliable power flow as well as energy efficiency. Therefore, the ability to analyze synchronized data from a variety of data sources within one system is essential in order to meet today's highest level of reliability, quality and energy efficiency and bring it into the future.

PQSCADA Sapphire's multi-vendor support sets new standards for power monitoring management software. This unique feature enables the gathering and analysis of all field generated data on a central software solution, regardless of IED manufacturer. PQSCADA Sapphire is an expandable platform - further capabilities can be easily added later with add-ons, or developed independently through the use of API to meet your custom needs and applications.

Accurate Data Anywhere, Anytime

Benefits

Multi-vendor support

PQSCADA Sapphire acquires, processes and stores recorded data from any recording device through a variety of communication protocols and file formats. PQSCADA Sapphire simplifies your IT environment by eliminating the need to purchase, install, train users and maintain multiple systems.

No Missed Events

PQSCADA Sapphire has sophisticated event detection capabilities enabling the devices to record only raw data. PQSCADA Sapphire will find events according to user defined thresholds during post-processing.

Access Information From Any Location

PQSCADA Sapphire data can be reached from any location using standard secured, firewall friendly protocols.

Get Notifications

PQSCADA Sapphire can be configured to send emails, SMS and pop-up notifications to users according to pre-configured scenarios.

Easily Fix Misconfigurations

PQSCADA Sapphire allows you to correct device installation and configuration errors by recalculating recorded data. Reverse Polarity, swap phases, connection type, VT/CT ratio and time inaccuracy can be corrected easily for both past and future measurements.

Reporting & Compliance Are Easy & Flexible

PQSCADA Sapphire has a flexible reporting and compliance engine allowing the design of report templates and compliance policies according to various standards or custom requirements. Reports can be generated manually or scheduled on a daily, weekly, monthly or yearly basis. Reports can also be triggered by compliance policy violation, or the occurrence of an event.

See the Whole Picture

Gain the most useful insights out of your data. PQSCADA Sapphire has a unique set of charts and reports empowering your ability to plan control and make data-driven decisions. Get an overview of your electrical network and measuring devices over geographic map.

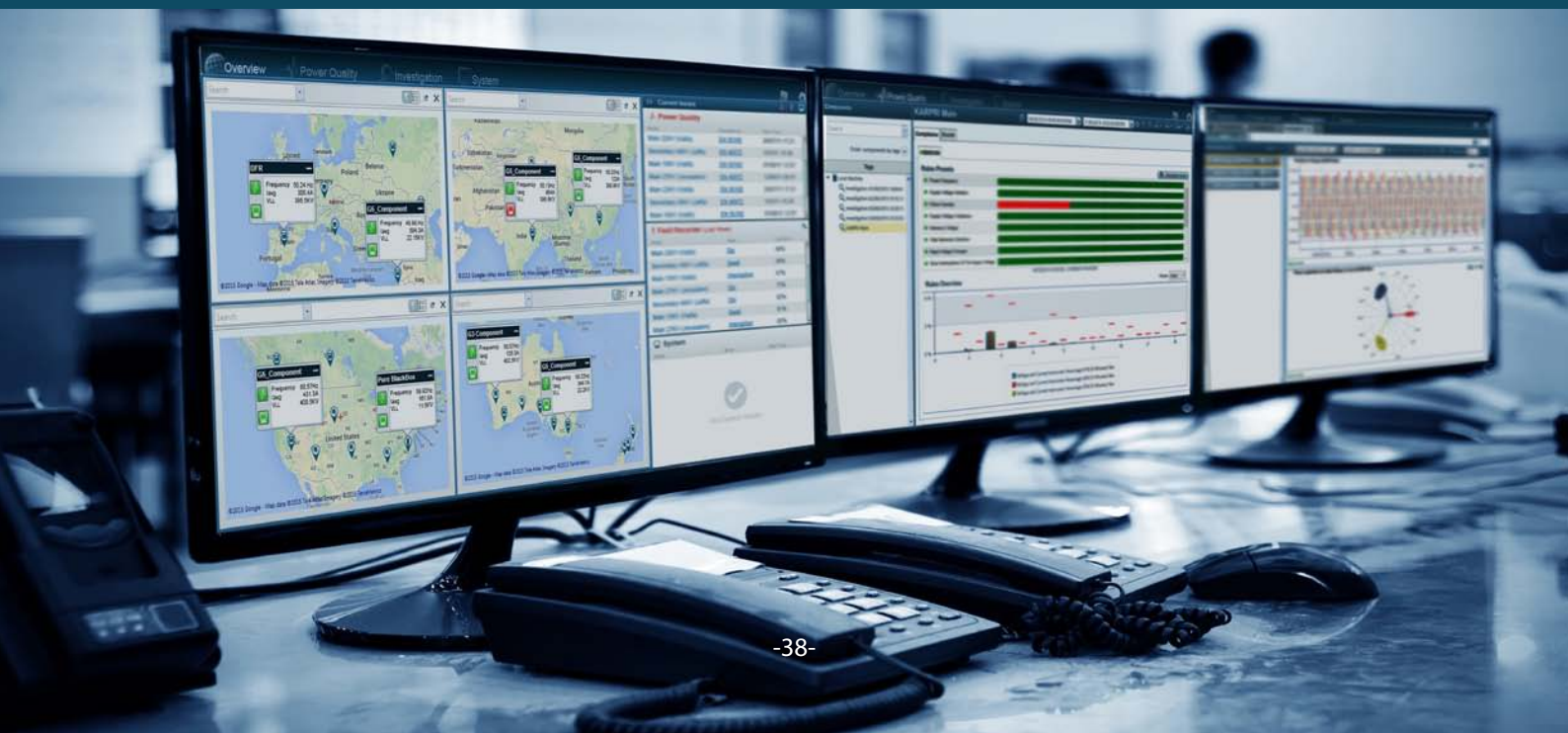

System Architecture

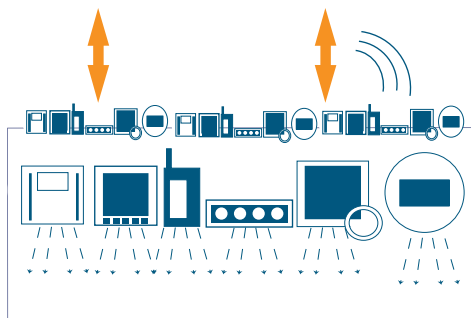
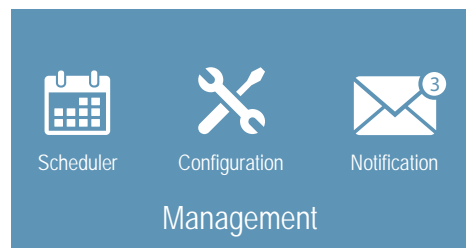
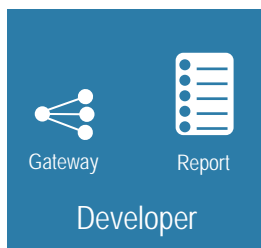

Data Acquisition & Process

Download: Vendor free Integration of Power Quality meters, fault recorders, protection devices, revenue meters and other IED's via standard protocols such as IEC 61850 and Modbus, or by importing COMTRADE/PQDIF files.

Process: Wide range of electrical parameters is calculated based on raw data. Processed data is stored efficiently for quick access, while keeping database size low.

PQSCADA Sapphire is capable of calculating 10,000 different power parameters, including statistics and harmonic amplitude/angle based on waveform raw data.

Storage: PQSCADA Sapphire supports a variety of DB engines such as MS SQL server 2008 and newer. Synchronized logged data, system data and events are securely stored at 1nsec precision. PQSCADA Sapphire supports distributed databases and servers for load balancing.

Developer

PQSCADA Sapphire is modular software enabling the user to extend capabilities and to meet any application and/or requirement. PQSCADA Sapphire supports two main add-on extensions:

Gateway: A comprehensive API is available for users who wish to extend PQSCADA Sapphire's communication options. The Gateway add-on can be designed to communicate through any industrial and proprietary communication protocol or file structure.

Report: The report add-on enables the user to design a tailored-made report template. Based on the stored data, the add-on also supports the option to calculate additional parameters and statistics, and to present it in the report.

Management

Scheduler: PQSCADA Sapphire supports a variety of automated tasks such as reporting, maintenance, upgrade and notification. The scheduler module allows the user to schedule the task to run automatically on hourly, weekly, monthly, or annually manner or to be triggered in the event of limit value violations.

Configuration: PQSCADA Sapphire configuration module allows the user to configure any parameter on the system including remote devices and servers.

Notification: emails or SMS notifications will be automatically sent in case of violation of thresholds of a predefined grid code, limit value violation, system error or any predefined event.



Investigation

The Investigation module graphically presents trends, histograms, events lists, summary tables, and statistical summaries of any stored parameters. It allows the user to analyze voltage sags/dips, swells, interruptions or any other incident. Each investigation includes multiple views and charts that can be easily exported to MS word with predefined template, a PDF file or to be stored as an image on your computer. Sharing an investigation between users of the system can be done with a single mouse click. PQSCADA Sapphire Multi-site investigation allows you to simultaneously view data from many different sites or instruments, to compare data from various locations or times in the same chart. Sophisticated event detection capabilities enable the user to configure events of any measured parameters and/or IO ports. The event mechanism supports out-of-limit events as well as rates of changed limits. Events can be configured with multiple thresholds and conditions with multiple parameters. Another feature of the event mechanism is the ability to aggregate multiple events with logic operation between them. The PQSCADA Sapphire will find events according to user defined thresholds during post-processing.

Trend chart

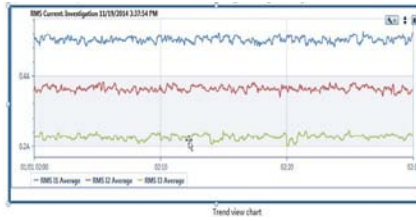

View parameters for a selected time range as one or more graphs where the horizontal axis represents the time range and the vertical axis represents the selected parameter

Grid chart

Time Range	[V1] RMS V1N Val...	[V1] RMS V1M Val...	[V1] RMS V1Y Val...	[V1] RMS V1B Val...	[V1] RMS I1	[V1] RMS I2	[V1] RMS I3
01/06/2018 10:00:00:000	227.7077	228.0157	229.0118	229.3892	228.8615	229.2121	229.2121
01/06/2018 10:00:01:750	227.7161	228.1589	229.0939	229.4087	228.8976	229.2462	229.2462
01/06/2018 10:00:03:500	227.7978	228.2828	229.0284	229.3109	228.9105	229.2488	229.2488
01/06/2018 10:00:05:250	227.7121	228.0381	228.9817	229.3588	228.7878	229.2520	229.2520
01/06/2018 10:00:07:000	227.5889	227.9689	228.9691	229.2498	228.7711	229.2399	229.2399
01/06/2018 10:00:08:750	227.8447	228.4711	228.7810	229.7477	228.8718	229.1566	229.1566
01/06/2018 10:00:10:500	228.028	228.3908	229.2054	229.7207	228.9858	229.044	229.044
01/06/2018 10:00:12:250	227.6883	228.4061	228.8641	229.6727	228.8054	229.1623	229.1623
01/06/2018 10:00:14:000	227.6893	227.8179	228.9942	229.1889	228.8128	229.1398	229.1398
01/06/2018 10:00:15:750	227.9461	227.9412	229.013	229.2677	228.8628	229.1476	229.1476
01/06/2018 10:00:17:500	227.8389	228.1287	229.1283	229.2963	228.9489	229.1218	229.1218
01/06/2018 10:00:19:250	227.8206	228.1421	229.0883	229.4444	229.0876	229.4378	229.4378
01/06/2018 10:00:21:000	227.8447	228.5854	229.2462	229.3989	229.1442	229.4388	229.4388
01/06/2018 10:00:22:750	227.8347	228.5844	229.1203	229.3277	229.0518	229.382	229.382

View selected parameters for selected time range as a table of values. The grid view table can be exported to Excel.

Summary chart

Parameter	Min	Max	Average
RMS V1N (Half Cycle)	4833.875 V	27862.38 V	12902.02 V
RMS V2N (Half Cycle)	219.7576 V	26134.37 V	12014.89 V
RMS V3N (Half Cycle)	48.39349 V	24405.08 V	12048.02 V
RMS I1 (Half Cycle)	2.637237 A	76.16993 A	26.58886 A
RMS I2 (Half Cycle)	3.15611 A	84.70454 A	27.08033 A
RMS I3 (Half Cycle)	3.779934 A	71.51199 A	26.70231 A
Active Power P123 (Cycle)	35991.68 W	2161166 W	889508.9 W

View the min, max & average of a given parameter within a definite period.

Event chart

ID	Name	Phase	Severity	Start Time	End Time	Duration	Value	Severity	Event Desc
5	FLICKERING	PHL	22	02/15/2012 04:34:40:100 PM	02/15/2012 04:34:40:100 PM	0:00:00:00	75.4428	22891913	System Dr
6	FLICKERING	PHL	22	02/15/2012 04:35:01:012 PM	02/15/2012 04:35:01:012 PM	0:00:00:00	75.4428	22891913	System Dr
4	HARMO_VOLTAGE_Chk...	PHL	38	02/15/2012 04:35:40:100 PM	02/15/2012 04:35:40:100 PM	0:00:00:00	8.2071	11205193	System Dr
7	HARMO_VOLTAGE_Chk...	PHL	44	02/15/2012 04:34:00:700 PM	02/15/2012 04:34:21:712 PM	0:00:01:700	8.2189	11279883	System Dr
7	SWELL	PHD	103	02/15/2012 04:34:10:254 PM	02/15/2012 04:34:21:714 PM	0:00:01:660	31.879	11279883	System Dr
7	HARMO_VOLTAGE_Chk...	PHL	38	02/15/2012 04:34:10:700 PM	02/15/2012 04:34:21:714 PM	0:00:01:014	5.5487	11289259	System Dr
4	INTERRUPTION	PHL	102	02/15/2012 04:34:10:700 PM	02/15/2012 04:34:21:714 PM	0:00:01:014	0.0000	18182245	System Dr
4	INTERRUPTION	PHL	102	02/15/2012 04:34:10:700 PM	02/15/2012 04:34:21:714 PM	0:00:01:014	0.0000	18182245	System Dr
4	INTERRUPTION	PHL	102	02/15/2012 04:34:10:700 PM	02/15/2012 04:34:21:714 PM	0:00:01:014	0.0000	18182245	System Dr

View system, power quality, I/O and custom events for selected time range as a table. It provides valuable information regarding the occurrence, duration and severity of those events

Spectrum chart

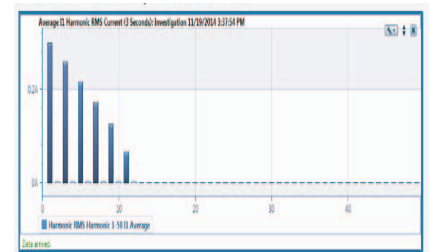

View selected parameters for selected time range as a column graph where the horizontal axis represents the harmonics and the vertical axis represents the amplitude of each harmonic. This allows you to view and investigate parameters on the frequency domain.



The PQZIP continuous recording enables to easily predict, prevent and troubleshoot issues without the need to set up triggers or thresholds in order to capture a specific event. With PQZIP the installation is straight forward!



PQSCADA Sapphires unique ca



Waveform of Line Voltage L1, L2, L3

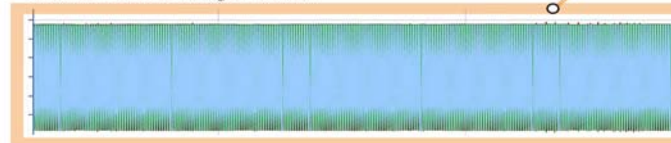

Waveform of Line Voltage L1, L2, L3

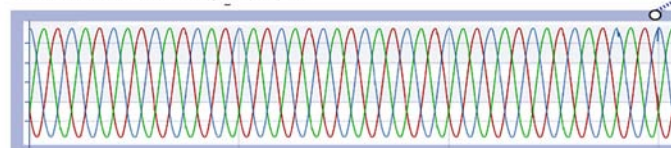

Statistics chart

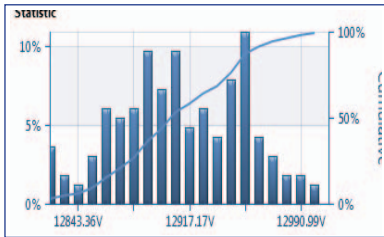

View selected parameters for selected time range. On the relative chart parameter values are divided into bins where each bin represents a range of values e.g., 230-231VAC. The chart's columns represent the percentage of time relative to a selected time range during which the parameter value equals each bin's range. On the cumulative chart, represented by the continuous line, each bin percentage value is accumulated to give graphic indication of the distribution of the bins range of values.

Phasor Diagram chart

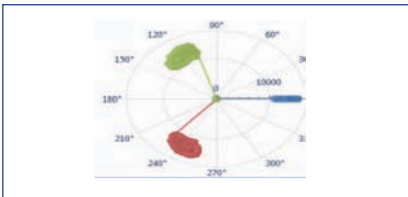

View the phasor amplitude and angle for a selected time range. The diagram also presents changes on both amplitude and phase during the selected time range.

Scatter chart

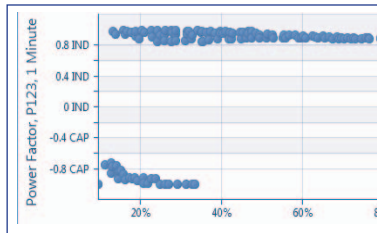

View selected parameters for selected time range as scattered dots. This allows to inspect the behavior of certain parameters in relation to another parameter where one of them is represented by the horizontal axis while the other is represented by the vertical axis.

Scatter Events chart

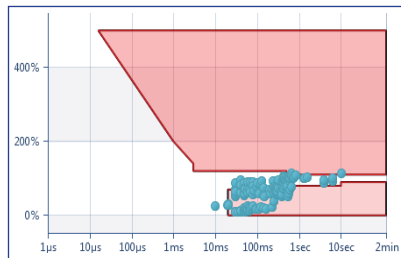

View selected events for selected time range according to international standards like CBEMA, NRS, ITIC, IEEE1668, and custom. This view scatters the events to allow a very clear view of the measurement point condition according to predefined areas in the graph output.

Cyclic Histogram Chart

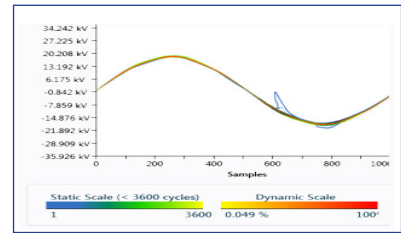

View overlaid voltage waveform cycles for a selected time range. This is made possible thanks to the unique continuous recording mechanism of Elspec analyzers. The histogram shows the deviation from the expected ideal waveform by overlaying the waveforms one on top of the other.

Energy chart

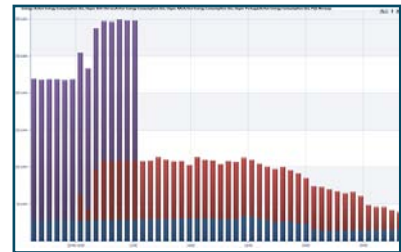

View the consumption and production of active/reactive and apparent energy for selected time range. View energy aggregation of different loads and generators. The energy chart is displayed in bars, trend or pie format

Ability to record waveform continuously @ 1024 s/c

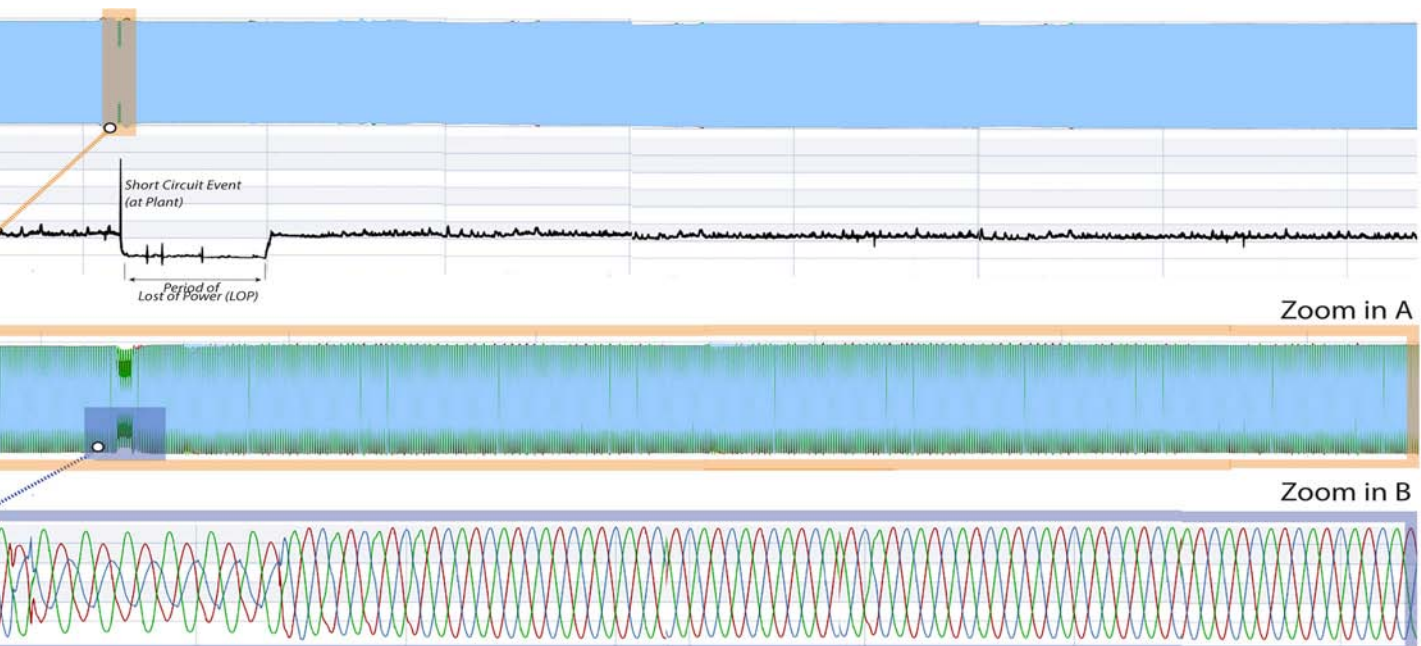

Overview

PQSCADA Sapphire enables you to view all measurement points on a live geographical map with real time data and general statuses. Each measurement point has two statuses:

- **Electrical:** Green as long as the electrical conditions at this specific measurement point are according to preconfigured grid code.
- **System:** Green as long as the measuring device is at operation condition.

In addition to the live map, 3 widgets are available to display the status of the electrical network:

- **Power quality:** the power quality widget displays a list of measurement points that are in violation with the preconfigured grid code. A link to map or investigation is available for quick access.
- **Disturbances:** the disturbances widget displays a list of short predefined events that have happened during the last hour/day/week/month. A link to map or investigation is available for quick access.
- **System:** the system widget displays a list of system messages/warnings about operation condition. A link to system module for further investigation is available.



Power Quality

The power Quality module shows at a glance the status of the entire network or individual measurement points for a selected period of time. The power quality conditions are configurable and can meet any power quality compliance standards such as the EN 50160 or any other local or international grid code. Identifying the root cause and type of violation is therefore quick and easy. Multiple compliance conditions can apply to single measurement point for comparison.

A comprehensive report, based on the power quality compliance conditions, can be easily generated from the power quality module.

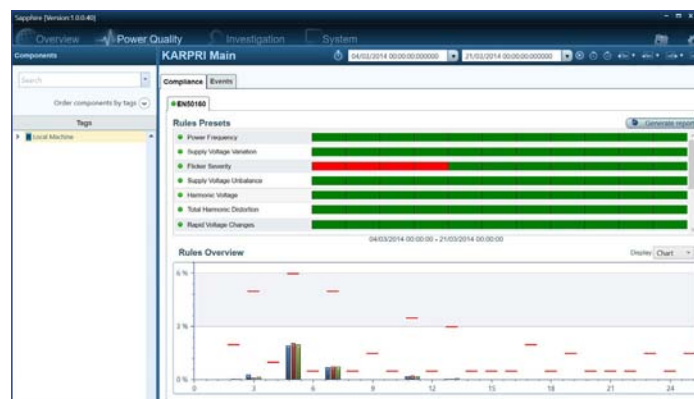

Product Selection Guide

Features	Express	Professional	Enterprise
Supported Parameters			
PQZIP	Import/Export	Import/Export	Import/Export
PQZ File	Import/Export	Import/Export	Import/Export
COMTRADE	Import/Export	Import/Export	Import/Export
PQDIP	Import/Export	Import/Export	Import/Export
Excel	Export	Export	Export
CSV	Export	Export	Export
PQZ HTTP/S		●	●
MODBUS		●	●
IEC 61850		●	●
Investigation			
Multi-site investigation	2	Unlimited	Unlimited
Trend Chart	●	●	●
Grid Chart	●	●	●
Summary Chart	●	●	●
Spectrum Chart	●	●	●
Statistics Chart	●	●	●
Event Chart	●	●	●
Scatter Event Chart	●	●	●
Scatter parameters chart		●	●
Cyclic Histogram		●	●
Phasors		●	●
Tasks			
Schedule task			●
Triggered by event			●
Reports			
Fault location		●	●
Server			
Security			●
Run as System Service			●
Client/Server Architecture			●
Servers Hierarchy			●
Client Module & Features			
Overview		●	●
Tags		●	●
Notifications			
Emails			●
SMS			●

Worldwide Innovator in Power Quality

Since 1988 Elspec has developed, manufactured and marketed proven power quality solutions far exceeding our clients' needs and expectations. Our innovations not only simplify the understanding of the quality of power itself, but are also highly compatible, making it suitable for any business and/or application. Elspec's international team of professionals with extensive experience in electrical engineering, are ready to provide a tailor-made strategy that will enable a sustainable and efficient use of your electrical energy.



International

Elspec Ltd.
info@elspec-ltd.com

North America

Quality Energy
info@quality-energy.com

Europe

Elspec Portugal Lda.
info@elspeceurope.com

India

Elspec Engineering India Pvt Ltd.
info@elspec.in

Región Andina

Elspec Andina
info@elspec.com.co

For all Products & Applications Visit us at:
www.quality-energy.com

