

Front view

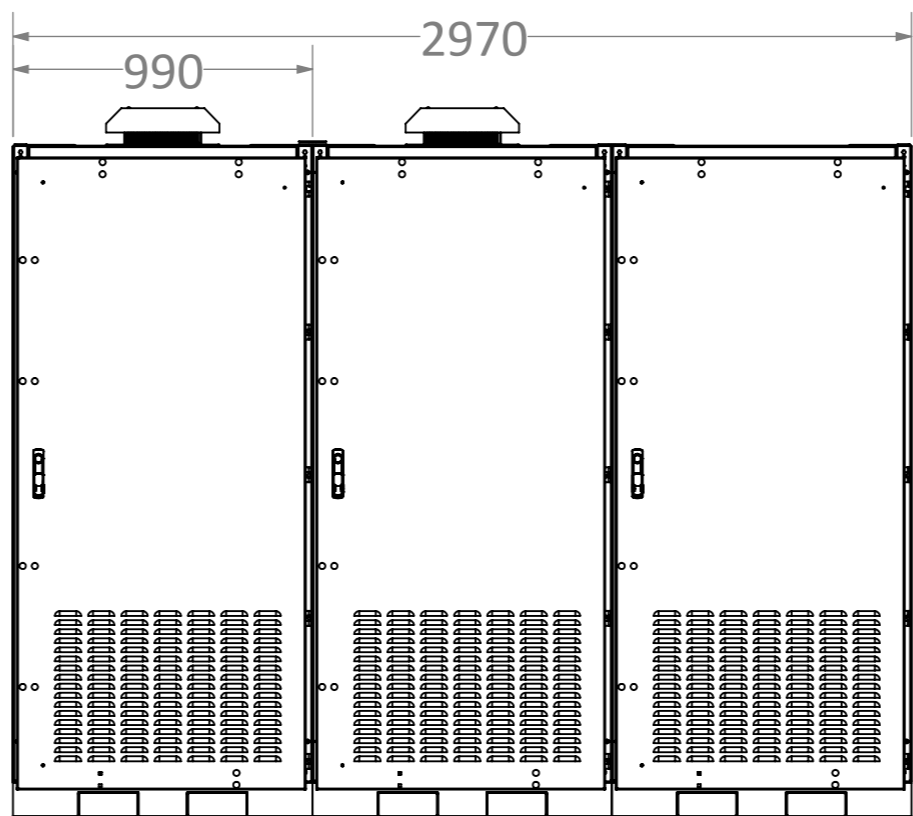

Rear view

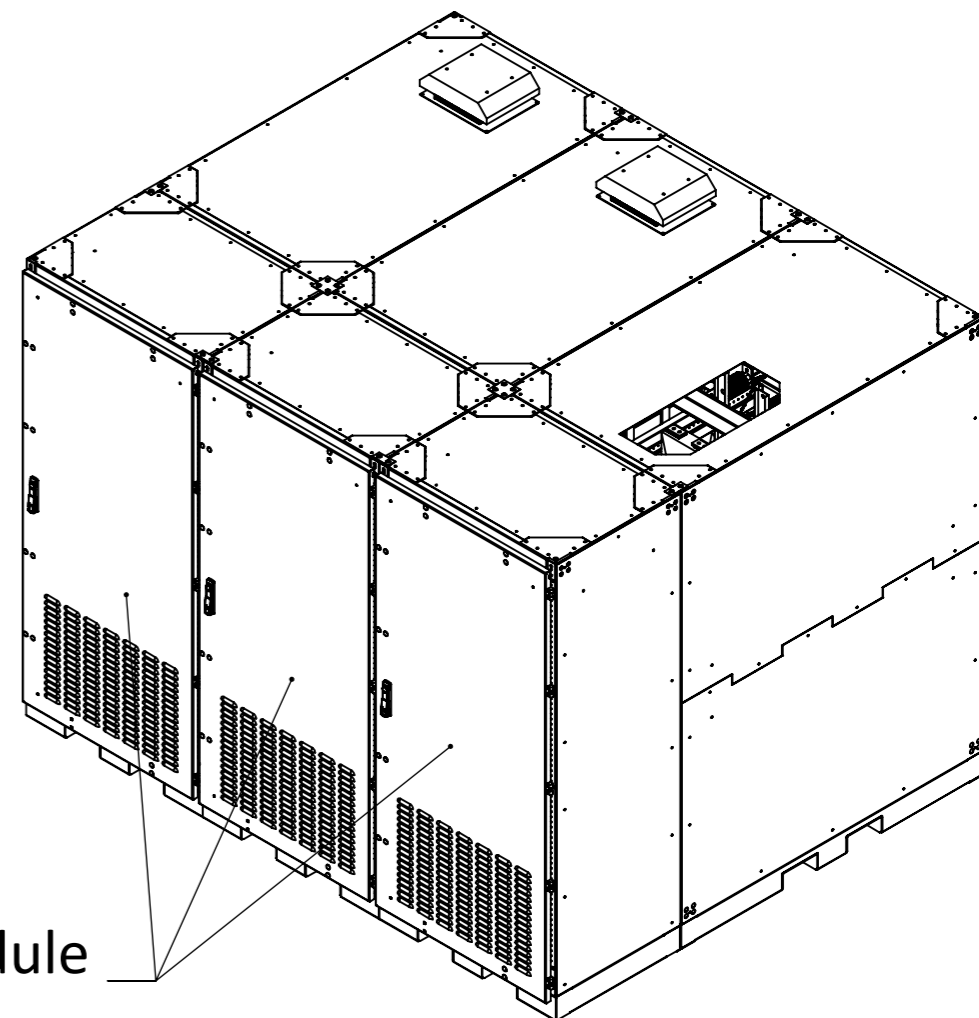

Switch module sections

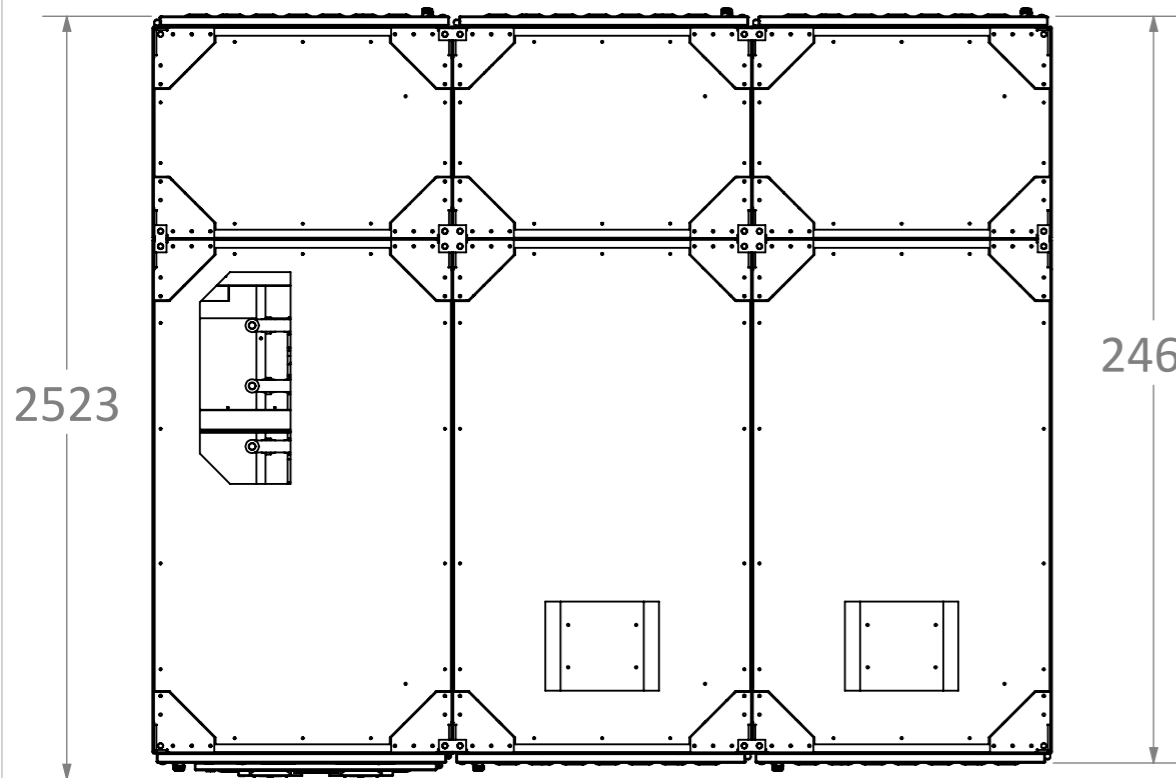

Top view

Cable entry

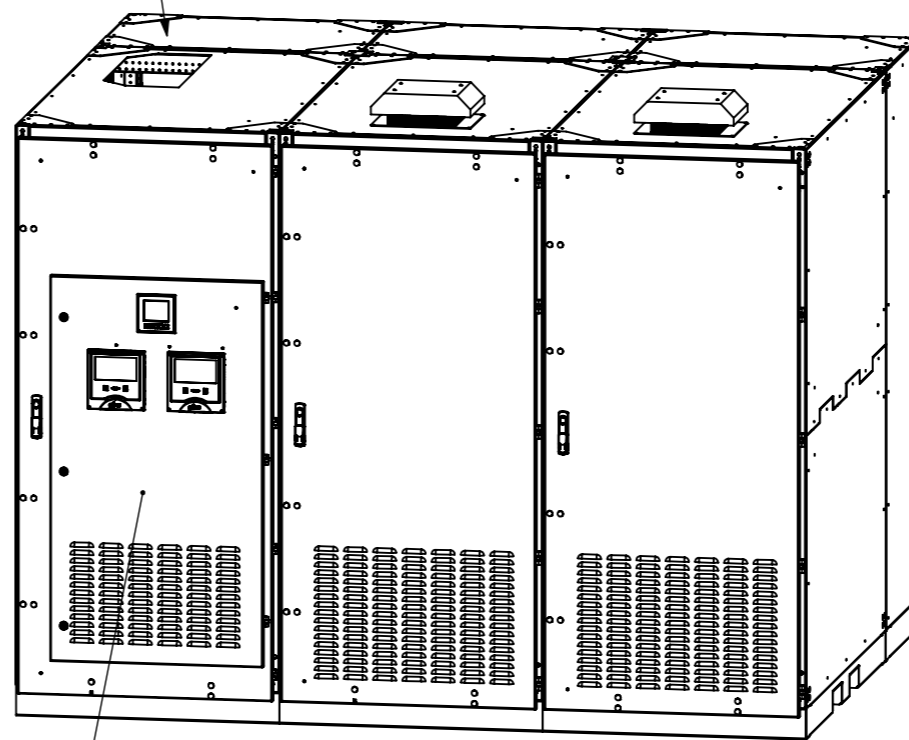

LV section

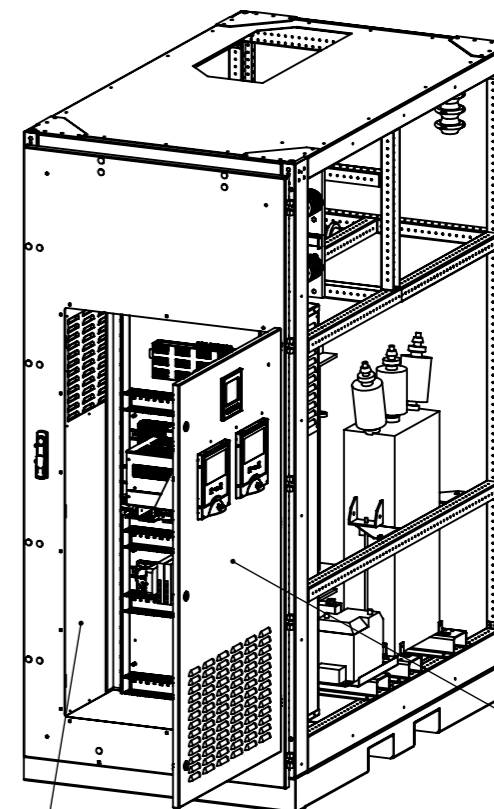

LV open door

Update: 15/08/2021

LV cabinet on door

TITLE: SHV-1532-0700		ECSPEC Tel: +972-4-6272470 Fax: +972-4-6272465	
DESCRIPTION: EQ1500:300:3-6900.60-P7-DFSA			
DES: Amram G.		UNLESS OTHERWISE SPECIFIED LINEAR TOLERANCES: ±1	
DRW: Amram G.		DIMENSIONS ARE IN MM DATE: 5.1.21	
CHK: Shevach G.		DWG NO: 00020346 SHEET: 1/4 REV:0	

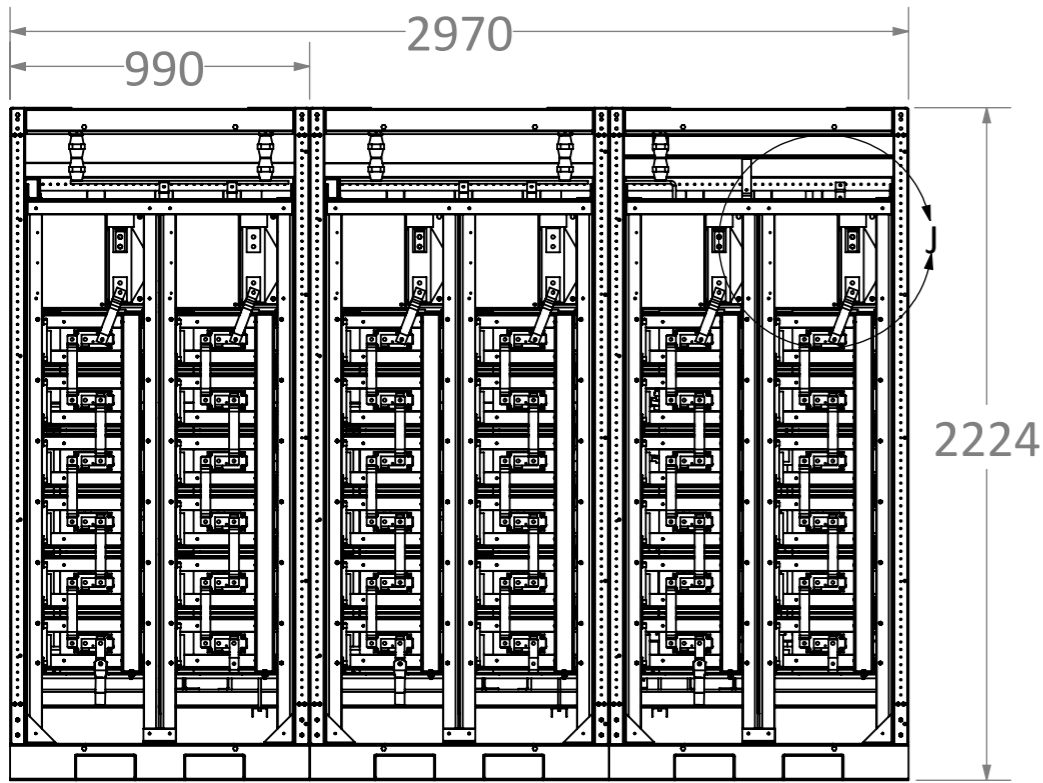

Front view

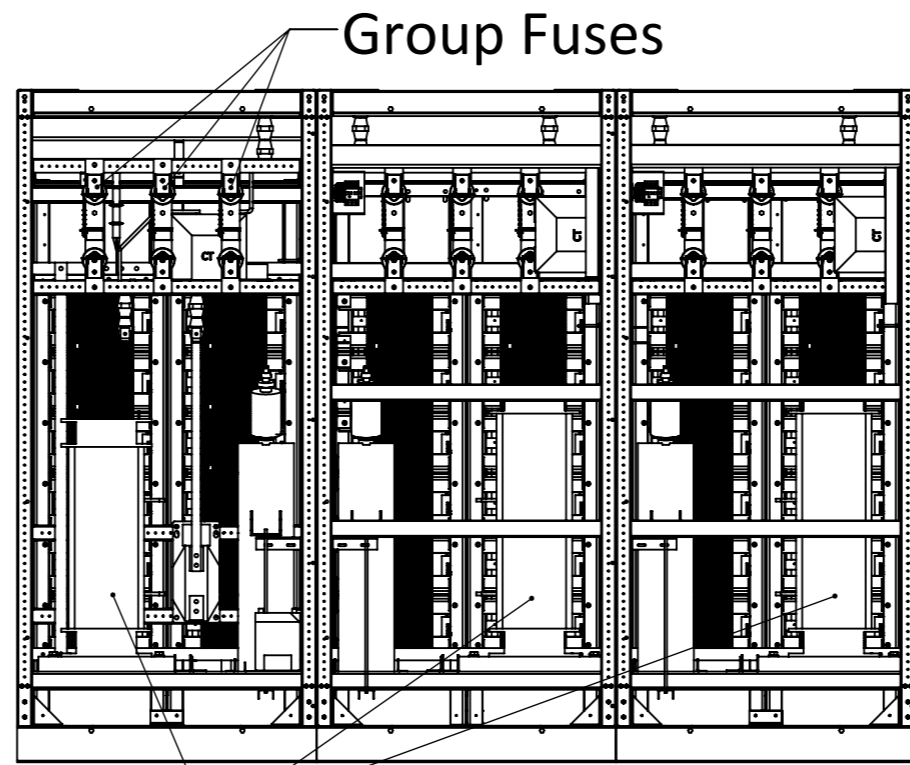

Rear view

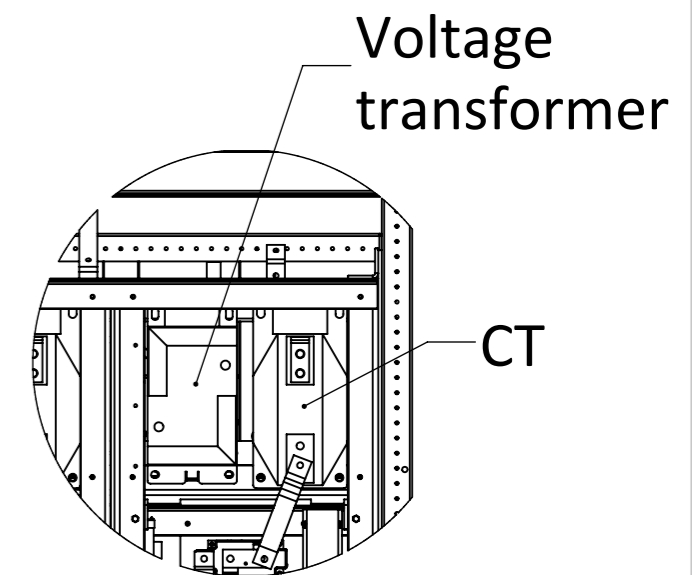
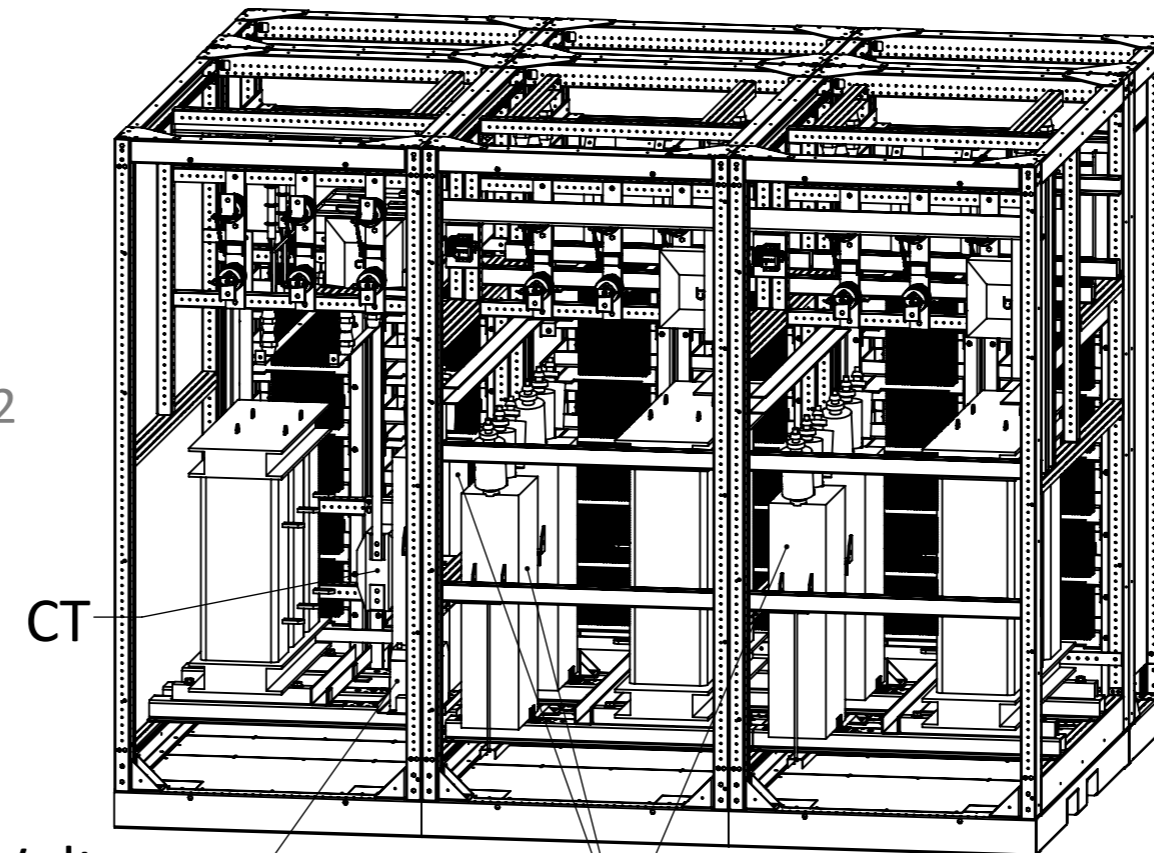
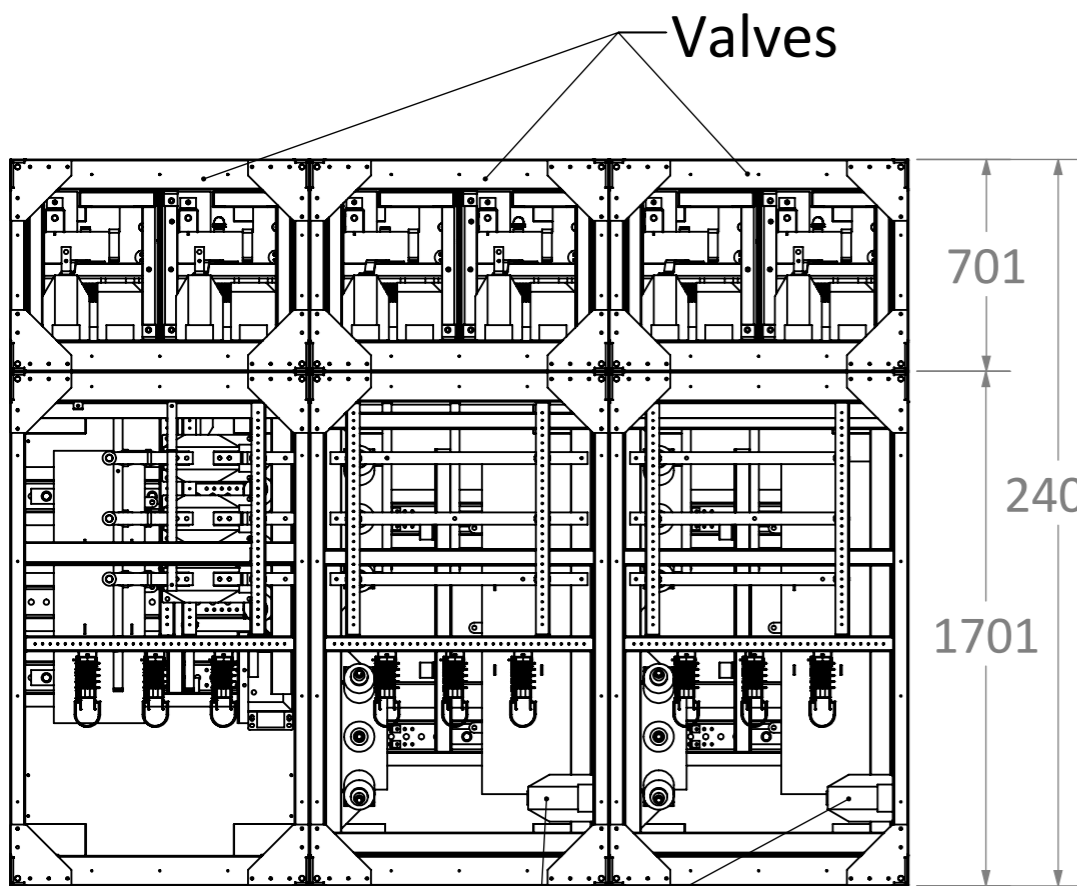
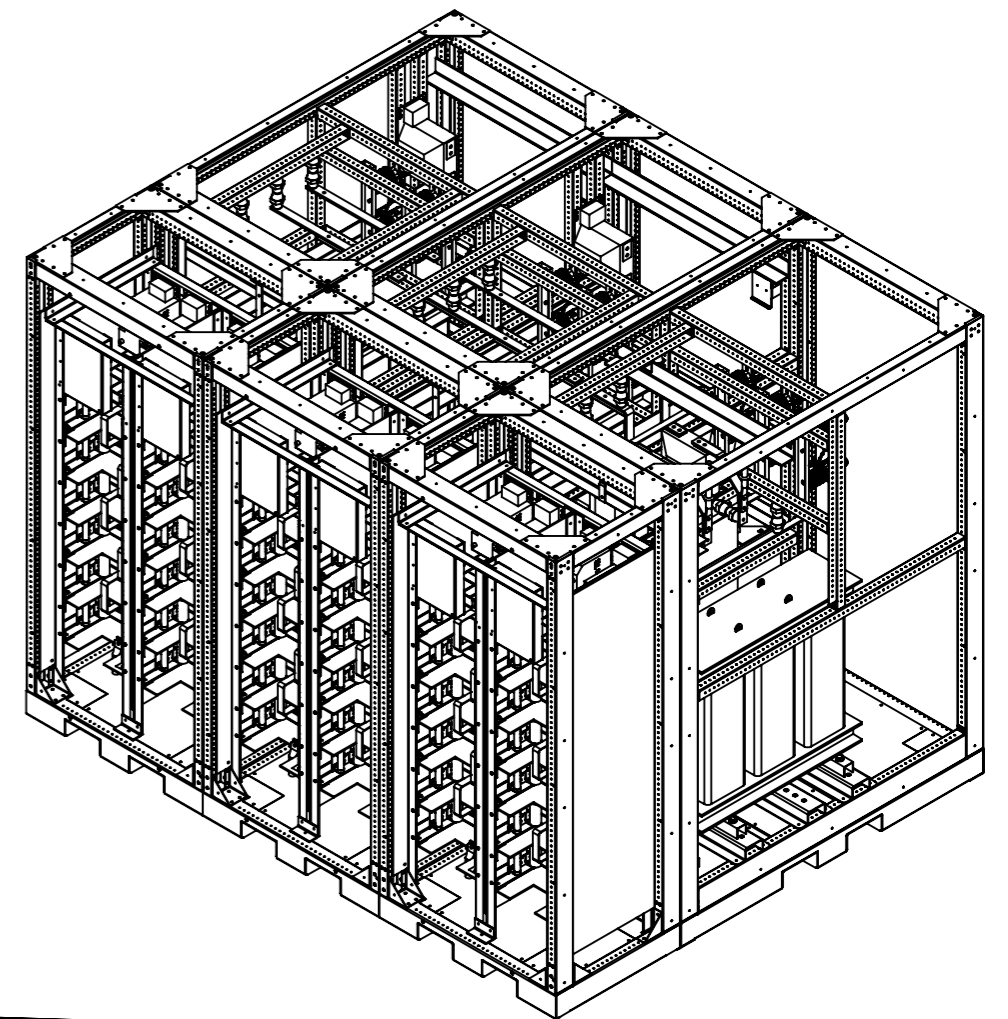

DETAIL J
SCALE 2 : 25

TITLE:		SHV-1532-0700		 Tel: +972-4-6272470 Fax: +972-4-6272465	
DESCRIPTION: EQ1500:300:3-6900.60-P7-DFSA					
DES: Amram G.		UNLESS OTHERWISE SPECIFIED LINEAR TOLERANCES: ±1			
DRW: Amram G.		DIMENSIONS ARE IN MM		DATE: 5.1.21	
CHK: Shevach G.		DWG NO: 00020346		SHEET: 2/4 REV:0	

Update: 15/08/2021

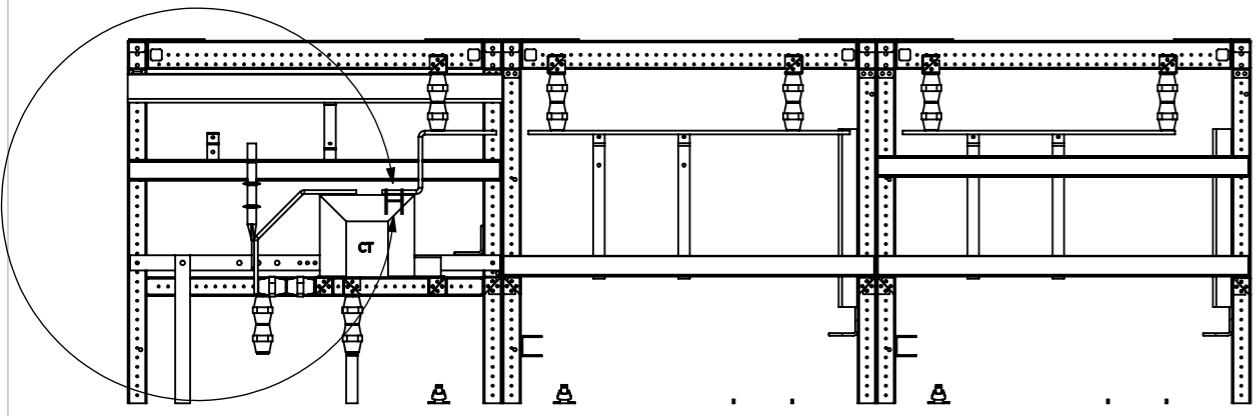

SECTION G-G
SCALE 1 : 20

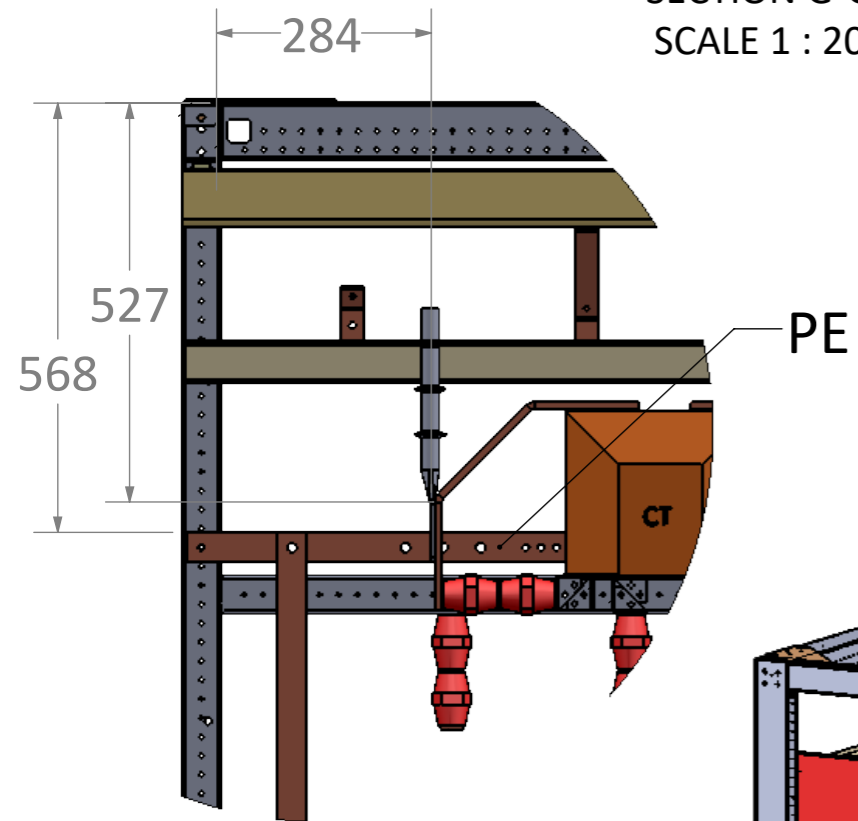

DETAIL H
SCALE 1 : 10

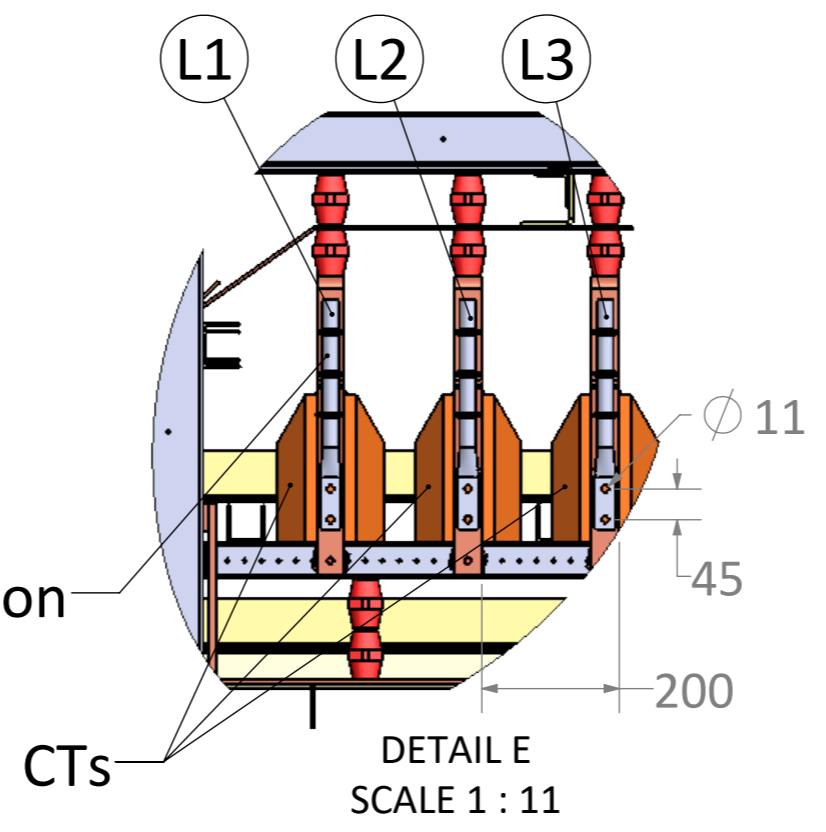

DETAIL E
SCALE 1 : 11

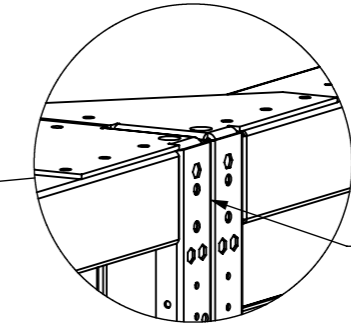
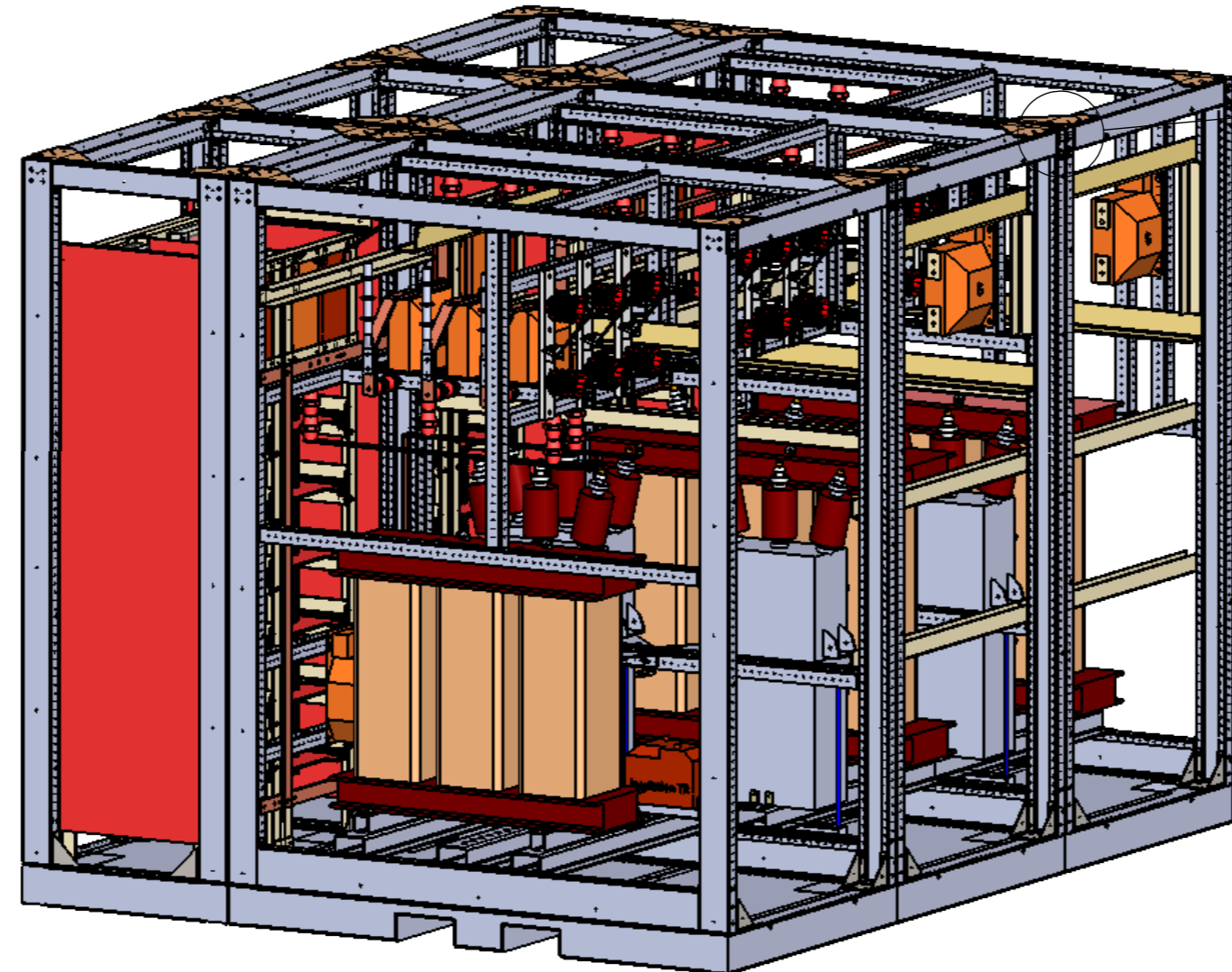
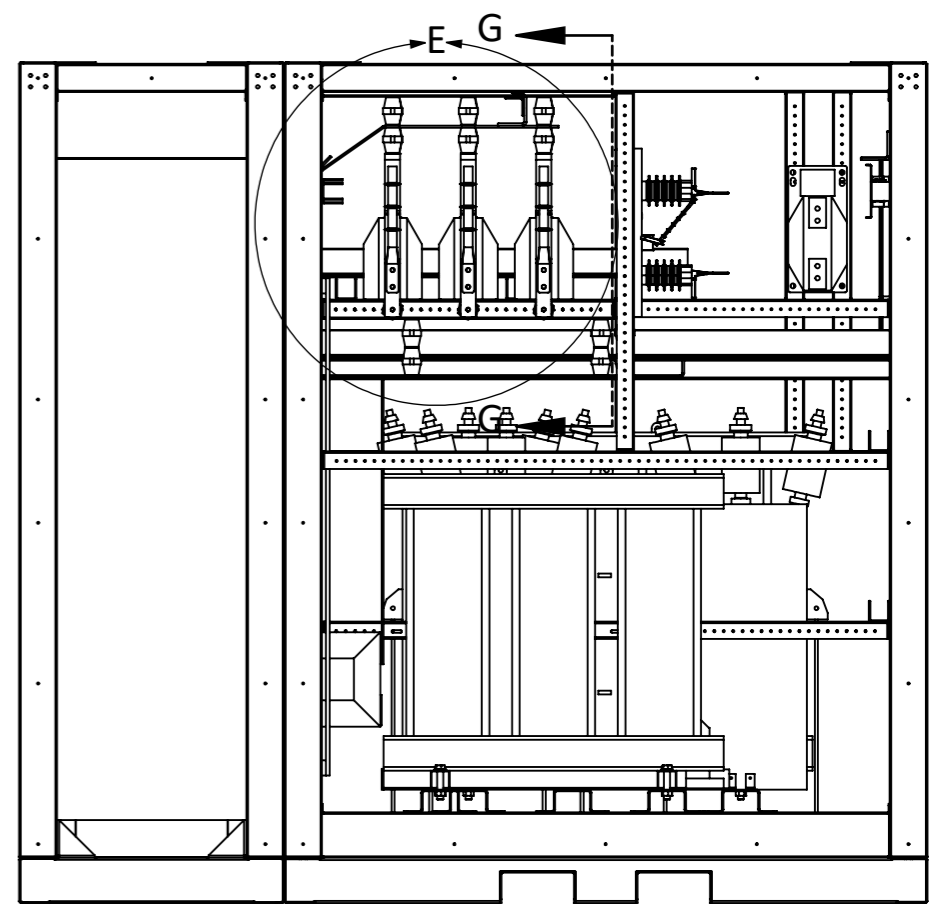

DETAIL K
SCALE 1 : 6

Remove screws between cabinets when placing them on site in order to match location limitations.

Update: 15/08/2021

TITLE: SHV-1532-0700			Tel: +972-4-6272470 Fax: +972-4-6272465		
DESCRIPTION: EQ1500:300:3-6900.60-P7-DFSA					
DES: Amram G.		UNLESS OTHERWISE SPECIFIED LINEAR TOLERANCES: ±1			
DRW: Amram G.		DIMENSIONS ARE IN MM			DATE: 5.1.21
CHK: Shevach G.		DWG NO: 00020346			SHEET: 3/4 REV:0

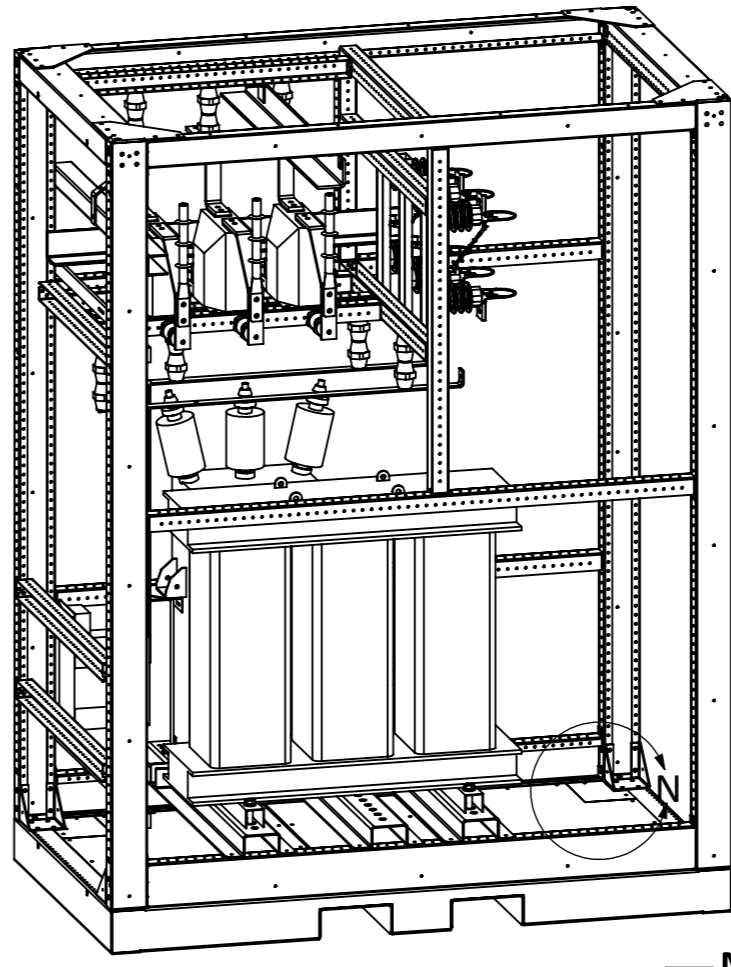
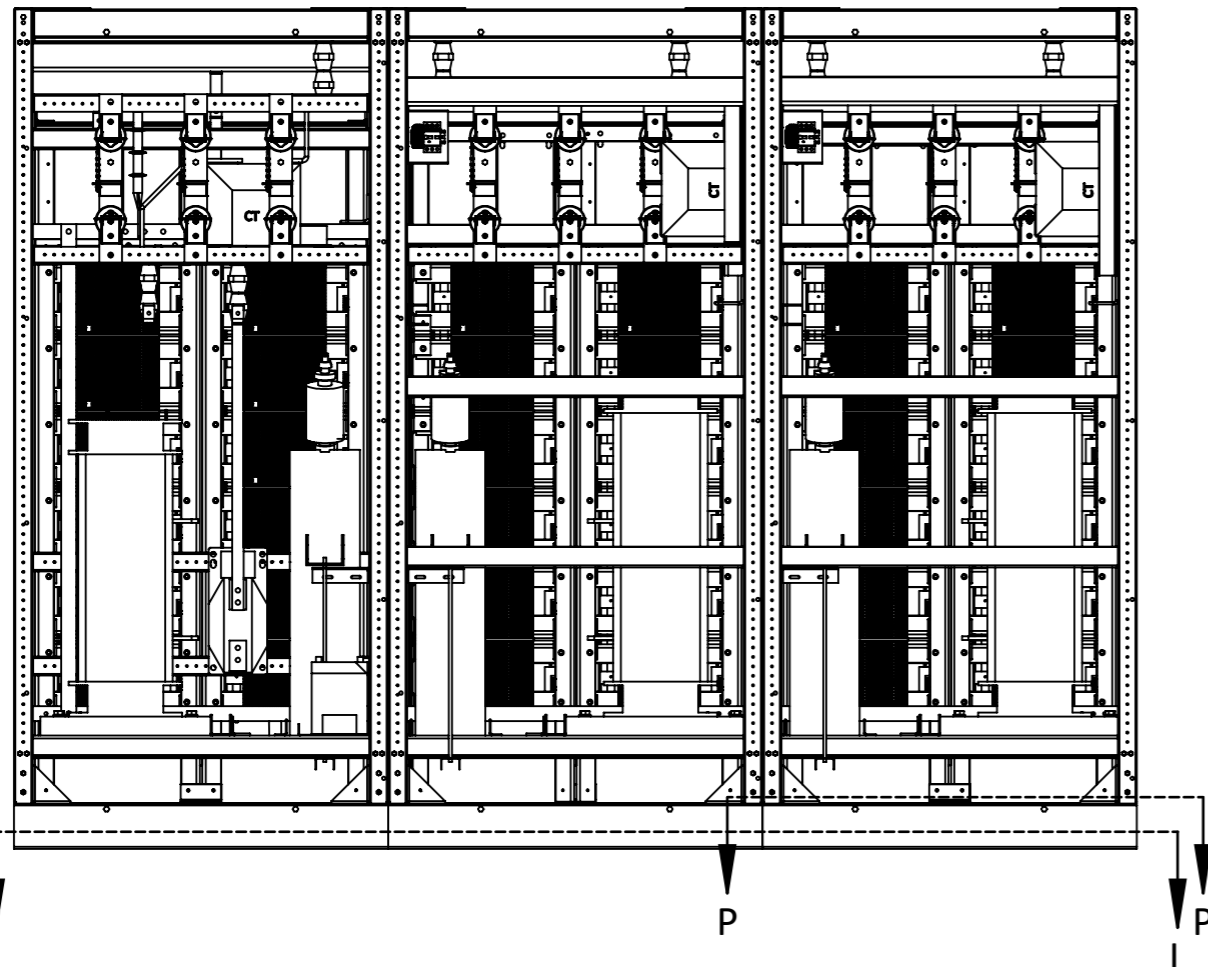

Anchor point

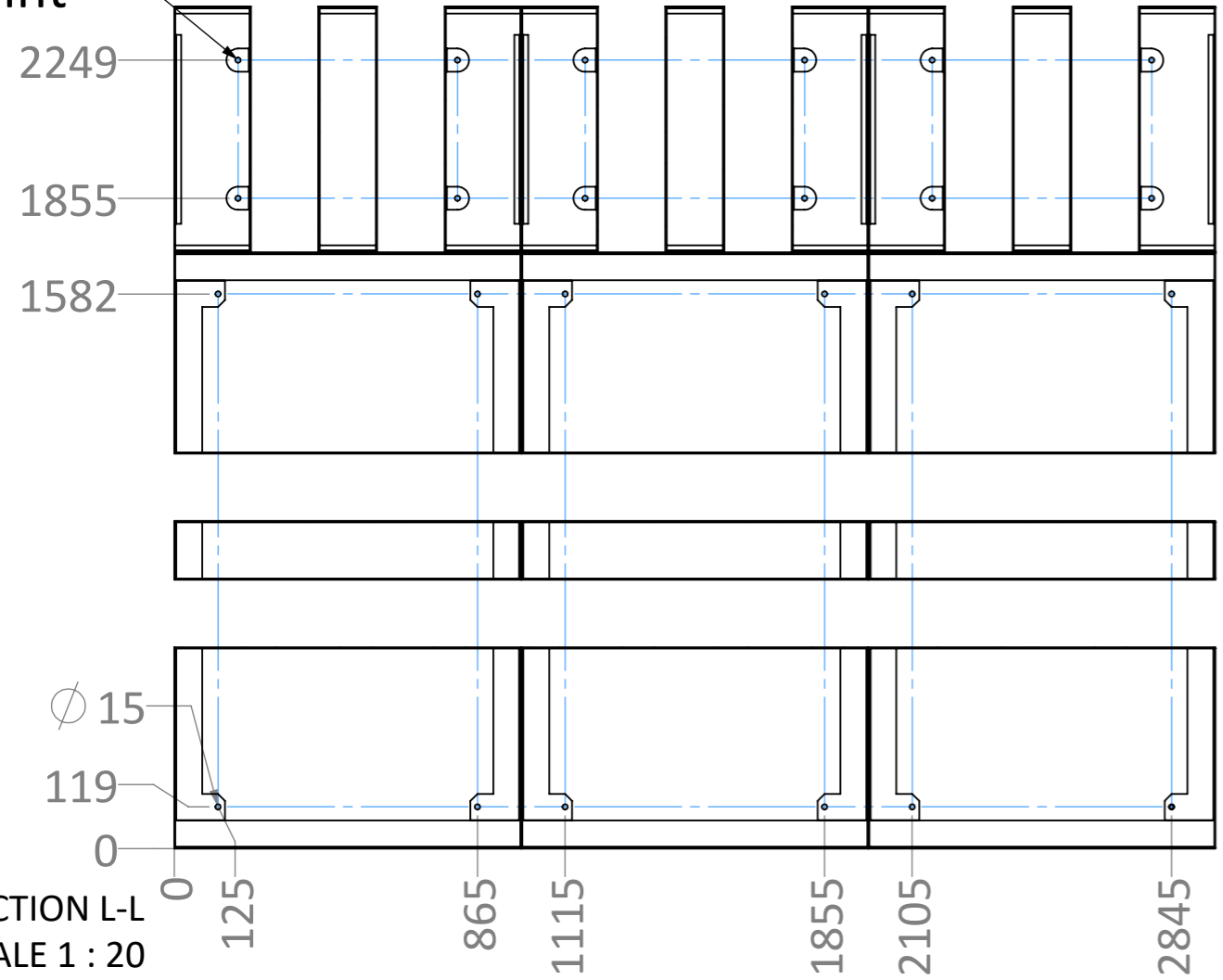

SECTION L-L
SCALE 1 : 20

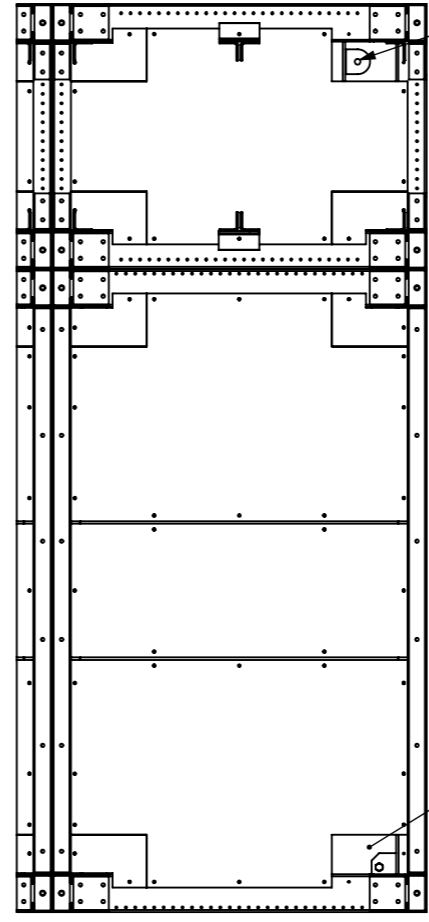

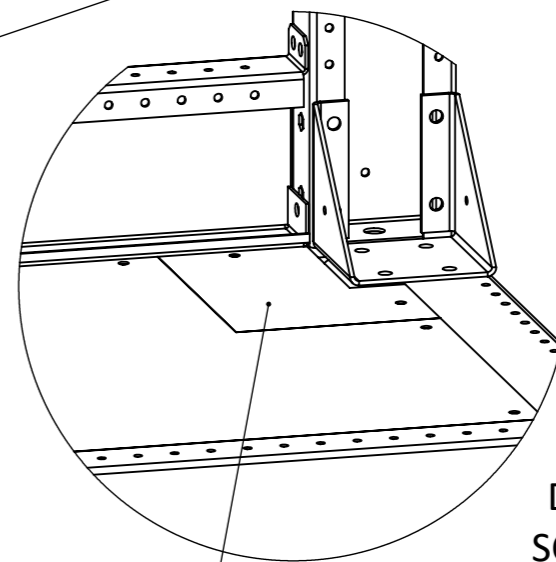

SECTION P-P
SCALE 1 : 20

M12 bolt (70Nm)



DETAIL N
SCALE 1 : 5

Remove corner covers to reach anchoring points

TITLE: SHV-1532-0700		 Tel: +972-4-6272470 Fax: +972-4-6272465	
DESCRIPTION: EQ1500:300:3-6900.60-P7-DFSA			
DES: Amram G.	UNLESS OTHERWISE SPECIFIED LINEAR TOLERANCES: ±1		
DRW: Amram G.	DIMENSIONS ARE IN MM		DATE: 5.1.21
CHK: Shevach G.	DWG NO: 00020346	SHEET: 4/4	REV: 0